

R88D-KN□□□-ML2, R88D-KT□

# Accurax G5 servo drive

Accurate motion control in a compact size servo drive family. MECHATROLINK-II motion bus and safety built-in.

- MECHATROLINK-II and Analog/ Pulse servo drive models
- Safety conforming ISO13849-1 Performance Level D
- High-response frequency of 2 kHz
- High resolution serial encoder for greater accuracy provided by 20 bits encoder
- External encoder input for full close loop
- Real time auto-tuning
- Advanced tuning algorithms (Anti-vibration function, torque feedforward, disturbance observer)

### Ratings

- 230 VAC Single-phase 100 W to 1.5 kW (8.59 Nm)
- 400 VAC three-phase 600 W to 5 kW (28.7 Nm)



AC Servo systems

## System configuration

### MECHATROLINK-II control

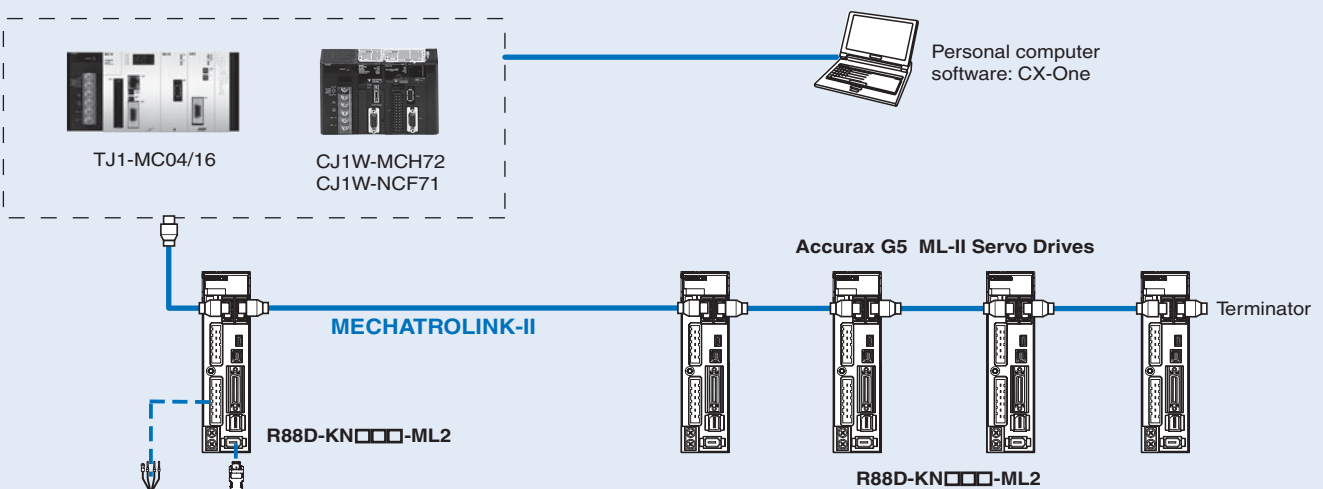

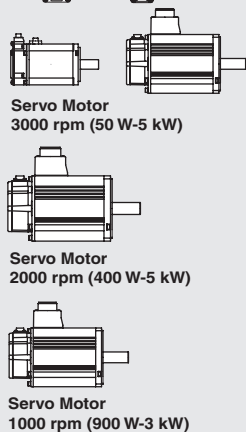

### Power cable Encoder cable

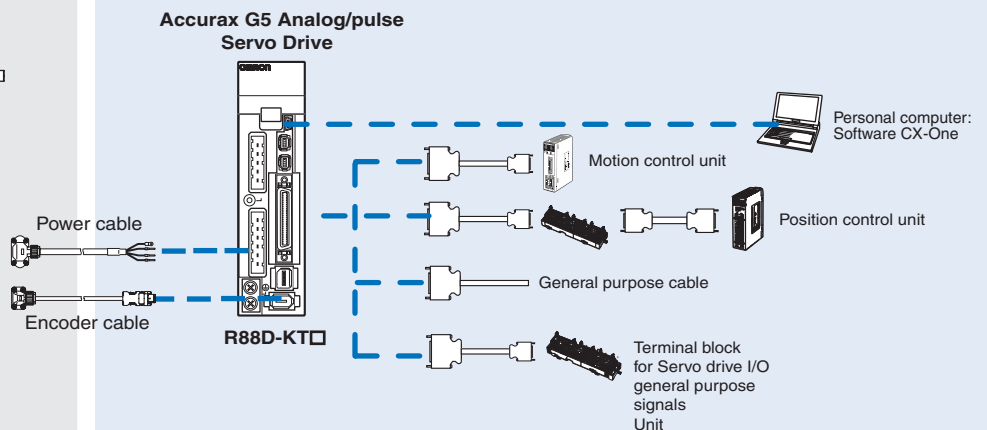

### Open Analog/pulse control



Servo motor supported

	Accurax G5 rotary servo motor					Accurax G5 servodrive					
	Voltage	Speed	Rated torque	Capacity	Model	MECHATROLINK-II model		Analog/Pulse model			
						230V	400V	230V	400V		
	230 V	3000 min <sup>-1</sup>	0.16 Nm	50 W	R88M-K05030(H/T)-□	R88D-KN01H-ML2	-	R88D-KT01H	-		
			0.32 Nm	100 W	R88M-K10030(H/T)-□	R88D-KN01H-ML2	-	R88D-KT01H	-		
			0.64 Nm	200 W	R88M-K20030(H/T)-□	R88D-KN02H-ML2	-	R88D-KT02H	-		
			1.3 Nm	400 W	R88M-K40030(H/T)-□	R88D-KN04H-ML2	-	R88D-KT04H	-		
			2.4 Nm	750 W	R88M-K75030(H/T)-□	R88D-KN08H-ML2	-	R88D-KT08H	-		
			3.18 Nm	1000 W	R88M-K1K030(H/T)-□	R88D-KN15H-ML2	-	R88D-KT15H	-		
			4.77 Nm	1500 W	R88M-K1K530(H/T)-□	R88D-KN15H-ML2	-	R88D-KT15H	-		
			2.39 Nm	750 W	R88M-K75030(F/C)-□	-	R88D-KN10F-ML2	-	R88D-KT10F	-	
			3.18 Nm	1000 W	R88M-K1K030(F/C)-□	-	R88D-KN15F-ML2	-	R88D-KT15F	-	
			4.77 Nm	1500 W	R88M-K1K530(F/C)-□	-	R88D-KN15F-ML2	-	R88D-KT15F	-	
	400 V	3000 min <sup>-1</sup>	6.37 Nm	2000 W	R88M-K2K030(F/C)-□	-	R88D-KN20F-ML2	-	R88D-KT20F		
			9.55 Nm	3000 W	R88M-K3K030(F/C)-□	-	R88D-KN30F-ML2	-	R88D-KT30F		
			12.7 Nm	4000 W	R88M-K4K030(F/C)-□	-	R88D-KN50F-ML2	-	R88D-KT50F		
			15.9 Nm	5000 W	R88M-K5K030(F/C)-□	-	R88D-KN50F-ML2	-	R88D-KT50F		
			230 V	2000 min <sup>-1</sup>	4.77 Nm	1000 W	R88M-K1K020(H/T)-□	R88D-KN10H-ML2	-	R88D-KT10H	-
			7.16 Nm		1500 W	R88M-K1K520(H/T)-□	R88D-KN15H-ML2	-	R88D-KT15H	-	
			1.91 Nm		400 W	R88M-K40020(F/C)-□	-	R88D-KN06F-ML2	-	R88D-KT06F	
			2.86 Nm		600 W	R88M-K60020(F/C)-□	-	R88D-KN06F-ML2	-	R88D-KT06F	
			4.77 Nm		1000 W	R88M-K1K020(F/C)-□	-	R88D-KN10F-ML2	-	R88D-KT10F	
			7.16 Nm		1500 W	R88M-K1K520(F/C)-□	-	R88D-KN15F-ML2	-	R88D-KT15F	
9.55 Nm	2000 W	R88M-K2K020(F/C)-□	-		R88D-KN20F-ML2	-	R88D-KT20F				
14.3 Nm	3000 W	R88M-K3K020(F/C)-□	-		R88D-KN30F-ML2	-	R88D-KT30F				
19.1 Nm	4000 W	R88M-K4K020(F/C)-□	-		R88D-KN50F-ML2	-	R88D-KT50F				
23.9 Nm	5000 W	R88M-K5K020(F/C)-□	-		R88D-KN50F-ML2	-	R88D-KT50F				
	230 V	1000 min <sup>-1</sup>	8.59 Nm	900 W	R88M-K90010(H/T)-□	R88D-KN15H-ML2	-	R88D-KT15H	-		
	400 V		8.59 Nm	900 W	R88M-K90010(F/C)-□	-	R88D-KN15F-ML2	-	R88D-KT15F		
			19.1 Nm	2000 W	R88M-K2K010(F/C)-□	-	R88D-KN30F-ML2	-	R88D-KT30F		
			28.7 Nm	3000 W	R88M-K3K010(F/C)-□	-	R88D-KN50F-ML2	-	R88D-KT50F		

Type designation

Servo drive

R88D-KN01H-ML2

Accurax G5 Series servo drive

Drive Type

T: Analog/pulse type  
N: Network type

Model

Blank: Analog/pulse type  
ML2: MECHATROLINK-II comms

Capacity and Voltage

Voltage	Code	Output
230 V	01H	100 W
	02H	200 W
	04H	400 W
	08H	750 W
	10H	1 kW
	15H	1.5 kW
400 V	06F	600 W
	10F	1.0 kW
	15F	1.5 kW
	20F	2.0 kW
	30F	3.0 kW
	50F	5.0 kW

**Servo drive specifications**

**Single-phase, 230 V**

Servo drive type		R88D-K□	01H□	02H□	04H□	08H□	10H□	15H□
Applicable servo motor	R88M-K□	05030(H/T)□	20030(H/T)□	40030(H/T)□	75030(H/T)□	1K020(H/T)□	1K030(H/T)□	
		10030(H/T)□	-	-	-	-	1K530(H/T)□	
		-	-	-	-	-	1K520(H/T)□	
		-	-	-	-	-	90010(H/T)□	
Max. applicable motor capacity	W	100	200	400	750	1000	1500	
Continuous output current	Arms	1.2	1.6	2.6	4.1	5.9	9.4	
Input power	Main circuit	Single-phase/3-phase, 200 to 240 VAC + 10 to -15% (50/60 Hz)						
Supply	Control circuit	Single-phase, 200 to 240 VAC + 10 to -15% (50/60 Hz)						
Control method		IGBT-driven PWM method, sinusoidal drive						
Feedback		Serial encoder (incremental/absolute value)						
Conditions	Usage/storage temperature	0 to +55°C / -20 to 65°C						
	Usage/storage humidity	90% RH or less (non-condensing)						
	Altitude	1000m or less above sea level						
Vibration/shock resistance (max.)		5.88 m/s <sup>2</sup> 10-60 Hz (Continuous operation at resonance point is not allowed) / 19.6 m/s <sup>2</sup>						
Configuration		Base mounted						
Approx. weight	Kg	0.8		1.1	1.6		1.8	

**Three-phase, 400 V**

Servo drive type		R88D-K□	06F-□	10F-□	15F-□	20F-□	30F-□	50F-□
Applicable servo motor	R88M-K□	40020(F/C)-□	75030(F/C)-□	1K030(F/C)-□	2K030(F/C)-□	3K030(F/C)-□	4K030(F/C)-□	
		60020(F/C)-□	1K020(F/C)-□	1K530(F/C)-□	2K020(F/C)-□	3K020(F/C)-□	5K030(F/C)-□	
		-	-	1K520(F/C)-□	-	2K010(F/C)-□	4K020(F/C)-□	
		-	-	90010(F/C)-□	-	-	5K020(F/C)-□	
Max. applicable motor capacity	kW	0.6	1.0	1.5	2.0	3.0	5.0	
Continuous output current	Arms	2.9		4.7	6.7	9.4	16.5	
Input power	Main circuit	3-phase, 380 to 480 VAC + 10 to -15% (50/60Hz)						
Supply	Control circuit	24 VDC ±15%						
Control method		IGBT-driven PWM method, sinusoidal drive						
Feedback		Serial encoder (incremental/absolute value)						
Conditions	Usage/storage temperature	0 to +55°C / -20 to +65°C						
	Usage/storage humidity	90% RH or less (non-condensing)						
	Altitude	1000 m or less above sea level						
Vibration/shock resistance		5.88 m/s <sup>2</sup> 10-60 Hz (Continuous operation at resonance point is not allowed) / 19.6 m/s <sup>2</sup>						
Configuration		Base mounted						
Approx. weight	Kg	1.9		2.7		4.7		

General specifications (for MECHATROLINK-II servo drives)

<b>Control mode</b>		Position control, velocity control, torque control, full-closed control.	
<b>Performance</b>	Frequency characteristics	2 kHz	
	Speed zero clamp	Preset velocity command can be clamped to zero by the speed zero clamp input.	
	soft start time setting	0 to 10 s (acceleration, deceleration can be set separately).	
<b>Command input</b>	MECHATROLINK-II communication	MECHATROLINK-II commands (for sequence, motion, data setting/reference, monitor, adjustment and other commands)	
<b>I/O signal</b>	Sequence input signal	- Multi-function input x 8 by parameter setting (forward/reverse drive prohibition, emergency stop, external latch, origin proximity, forward/reverse torque limit, general purpose monitor input).	
	Sequence output signal	It is possible to output three types of signal form incl.: brake release, servo ready, servo alarm, positioning complete, motor rotation speed detection, torque limit detection, zero speed detection, speed coincidence detection, warning, position command status, speed limit detection, alarm output, speed command status.	
<b>USB communications</b>	Interface	Personal computer/ Connector mini-USB	
	Communications standard	Compliant with USB 2.0 standard	
	Function	Parameter setting and status monitoring	
	<b>MECHATROLINK-II communications</b>	Communications protocol	MECHATROLINK-II
		Station address	41H to 51 FH (max. number of slaves: 30)
		Transmission speed	10 Mbps
Transmission cycle		1, 2 & 4 ms	
Data length	32 bytes		
<b>Integrated functions</b>	Automatic load inertia detection	Automatic motor parameter setting. One parameter rigidity setting.	
	Dynamic brake (DB)	Built-in. Operates during main power OFF, servo alarm, servo OFF or overtravel.	
	Regenerative processing	Internal resistor included in models from 600 W to 5 kW. Regenerative resistor externally mounted (option).	
	Overtravel (OT) prevention function	DB stop, deceleration stop or coast to stop during P-OT, N-OT operation	
	Encoder divider function	Optional division possible	
	Protective functions	Overcurrent, overvoltage, undervoltage, overspeed, overload, encoder error, overheat...	
	Analog monitor functions for supervision	Analog monitor of motor speed, speed reference, torque reference, command following error, analog input... The monitoring signals to output and their scaling can be specified with parameters. Number of channels: 2 (Output voltage: ±10V DC)	
	Panel operator	Display functions	2-digit 7-segment LED display shows the drive status, alarm codes, parameters...
		Switches	MECHATROLINK-II communications status LED indicator (COM) 2 x rotary switches for setting the MECHATROLINK-II node address
	CHARGE lamp	Lits when the main circuit power supply is turned ON.	
	Safety terminal	Functions	Safety Torque OFF function to cut off the motor current and stop the motor. Output signal for failure monitoring function.
Conformed standards		EN ISO13849-1:2008 (PL- d, Performance Level d), IEC61800-5 -2:2007 (function STO, Safe Torque OFF), EN61508:2001 (Safety Integrity Level 2, SIL2), EN954-1:1996 (CAT3).	
External encoder feedback	Serial signal and line-driver A-B-Z encoder for full-close control		

General specifications (for analog/pulse servo drives)

<b>Control mode</b>		7 modes selectable by parameter: (1) position control, (2) velocity control, (3) torque control, (4) position/velocity control, (5) position/torque control, (6) velocity/torque control and (7) full-closed control.	
<b>Performance</b>	Frequency characteristics	2 kHz	
	Speed zero clamp	Preset velocity command can be clamped to zero by the speed zero clamp input.	
	Soft start time setting	0 to 10 s (acceleration, deceleration can be set separately). S-curve acceleration/deceleration is also available.	
	<b>Speed/torque control</b>	Speed control	Speed reference voltage
Torque limit			3 VDC at rated torque (torque can be limited separately in positive/negative direction).
Torque control		Preset speed control	Preset speed is selectable from 8 internal settings by digital inputs.
<b>Position control</b>	Input pulse	Torque reference voltage	3 VDC at rated torque: set at delivery (the scale and polarity can be set by parameters).
		Speed limit	Speed limit can be set by parameter.
		Input pulse type	Sign + pulse train, 90° phase displacement 2-phase pulse (A-phase+ B-phase) or CCW/CW pulse train
<b>Full-closed control</b>	Input pulse	Input pulse frequency	4 Mpps max. (200 Kpps max. at open collector).
		Command pulse scaling (Electronic Gear)	Applicable scaling ratio: 1/1000 - 1000 Any value of 1-2 <sup>30</sup> can be set for numerator (encoder resolution) and denominator (command pulse resolution per motor revolution). The combination has to be within the range shown above.
		Input pulse type	Sign + pulse train, 90° phase displacement 2-phase pulse (A-phase+ B-phase) or CCW/CW pulse train
		Input pulse frequency	4 Mpps max. (200 Kpps max. at open collector).
<b>I/O signal</b>	External encoder scaling	Command pulse scaling (Electronic Gear)	Applicable scaling ratio: 1/1000 - 1000 Any value of 1-2 <sup>30</sup> can be set for numerator (encoder resolution) and denominator (command pulse resolution). The combination has to be within the range shown above.
		External encoder scaling	Applicable scaling ratio: 1/20 - 160 Any value of 1-2 <sup>30</sup> can be set for numerator (encoder resolution) and denominator (external encoder resolution per motor revolution). The combination has to be within the range shown above.
		Position signal output	A-phase, B.phase, Z-phase line driver output and Z-phase open-collector output.
<b>I/O signal</b>	Sequence input signal	- Multi-function input x 10 by parameter setting (servo ON, control mode switching, forward/reverse drive prohibition, vibration filter switching, gain switching, electronic gear switching, error counter reset, pulse prohibition, alarm reset, internal speed selection, torque limit switching, zero speed, emergency stop, inertia ratio switching, velocity/torque command sign).  - Dedicated input x 1 (SEN: sensor ON, ABS data request).	
	Sequence output signal	It is possible to output four types of signal form incl.: brake release, servo ready, servo alarm, positioning complete, motor rotation speed detection, torque limit detection, zero speed detection, speed coincidence detection, warning, position command status, speed limit detection, speed command status.	

Integrated functions	USB Communications	Interface	Personal computer/ Connector mini-USB	
		Communications standard	Compliant with USB 2.0 standard	
		Function	Parameter setting and status monitoring	
		Automatic load inertia detection	Automatic motor parameter setting. One parameter rigidity setting.	
		Dynamic brake (DB)	Built-in. Operates during main power OFF, servo alarm, servo OFF or overtravel.	
		Regenerative processing	Internal resistor included in models from 600 W to 5 kW. Regenerative resistor externally mounted (option).	
		Overtravel (OT) prevention function	DB stop, deceleration stop or coast to stop during P-OT, N-OT operation	
		Encoder divider function	Optional division possible	
		Electronic gearing (Numerator/Denominator)	Up to 4 electronic gear numerators by combining with inputs.	
		Internal speed setting function	8 speeds may be set internally	
		Protective functions	Overcurrent, overvoltage, undervoltage, overspeed, overload, encoder error, overheat...	
		Analog monitor functions for supervision	Analog monitor of motor speed, speed reference, torque reference, command following error, analog input... The monitoring signals to output and their scaling can be specified by parameters. Number of channels: 2 (Output voltage: ±10V DC)	
		Panel operator	Display functions	6-digit 7-segment LED display shows the drive status, alarm codes, parameters...
			Panel operator keys	Used to set/monitor parameters and drive condition (5 key switches).
		CHARGE lamp		Lits when the main circuit power supply is turned ON.
		Safety terminal	Functions	Safety torque OFF function to cut off the motor current and stop the motor. Output signal for failure monitoring function.
			Conformed standards	EN ISO13849-1:2008 (PL- d, Performance Level d), IEC61800-5 -2:2007 (function STO, Safe Torque OFF), EN61508:2001 (Safety Integrity Level 2, SIL2), EN954-1:1996 (CAT3).
		External encoder feedback		Serial signal and line-driver A-B-Z encoder for full-close control
		Expansion connector		Serial bus for option board

Servo drive part names

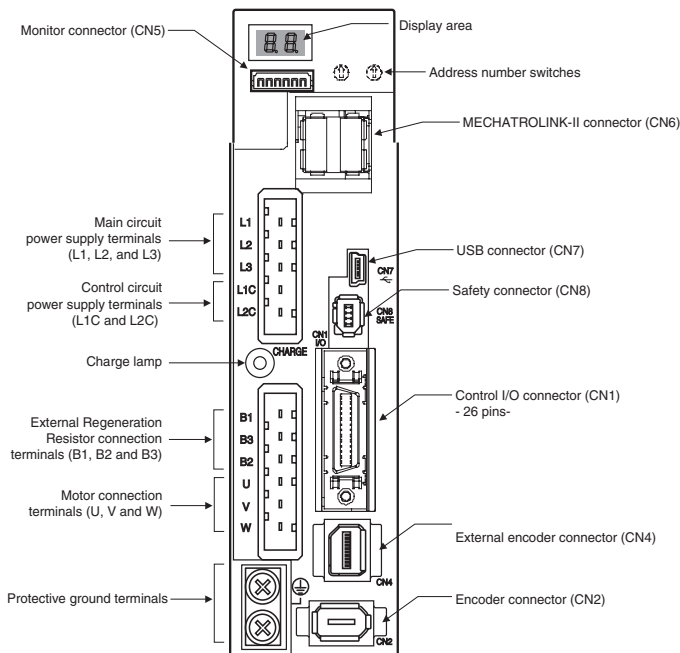

MECHATROLINK-II servo drives

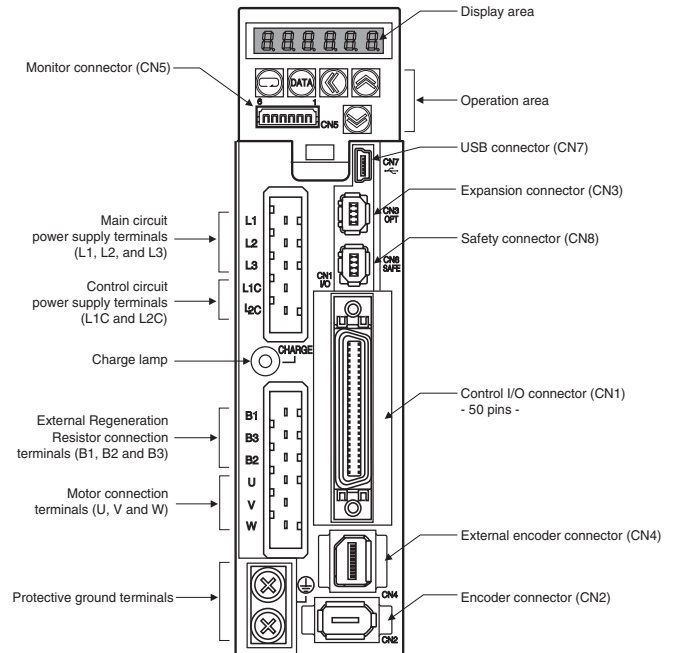

Analog/pulse servo drives

**Note:** the above pictures show 230 V servo drives models only. The 400 V servo drives have 24 VDC power input terminals for control circuit instead of L1C and L2C terminals.

## I/O specifications

### Terminals specifications (for all drives)

Symbol	Name	Function
L1	Main power supply input terminal	AC power input terminals for the main circuit  Note: for single-phase servo drives connect the power supply input to L1 and L3.
L2		
L3		
L1C	Control power supply input terminal	AC power input terminals for the control circuit (for 200V single/three-phase servo drives only).
L2C		DC power input terminals for the control circuit (for 400V three-phase servo drives only).
24 V		
0 V		
B1	External regeneration resistor connection terminals	Servo drives below 750W: no internal resistor is connected. Leave B2 and B3 open. Connect an external regenerative resistor between B1 and B2.
B2		
B3		Servo drives from 750W to 5 kW: short-circuit in B2 and B3 for internal regenerative resistor. If the internal regenerative resistor is insufficient, connect an external regenerative resistor between B1 and B2 and remove the wire between B2 and B3.
U	Servo motor connection terminals	Terminals for outputs to the servomotor.
V		
W		

### I/O signals (CN1) - Input signals (for MECHATROLINK-II servo drives)

Pin No.	Signal name	Function
6	I-COM	± pole of external DC power. The power must use 12V-24V (±5%)
5	E-STOP	Emergency stop
7	P-OT	Forward run prohibited
8	N-OT	Reverse run prohibited
9	DEC	Origin proximity
10	EXT3	External latch input 3
11	EXT2	External latch input 2
12	EXT1	External latch input 1
13	SI-MON0	General purpose monitor input 0
14	BTP-I	Connecting pin for the absolute encoder backup battery. Do not connect when a battery is connected to the encoder cable (CN2 connector).
15	BTN-I	
17	-	Terminals not used. Do not connect.
18	-	
19	-	
20	-	
21	-	
22	-	
23	-	
24	-	
-	PCL	Forward torque limit
-	NCL	Reverse torque limit
-	SI-MON1	General-purpose monitor input 1
-	SI-MON2	General-purpose monitor input 2
Shell	FG	Shield ground. Connected to frame ground if the shield wire of the I/O signal cable is connected to the connector shell.
16	GND	Signal ground. It is insulated with power supply (I-COM) for the control signal in the servo drive.

### I/O signals (CN1) - output signals (for MECHATROLINK-II servo drives)

Pin No.	Signal name	Function
1	BRK-OFF+	External brake release signal
2	BRK-OFF	
25	S-RDY+	Servo ready: ON when there is no servo alarm and control/main circuit power supply is ON
26	S-RDY-	
3	ALM+	Servo alarm: Turns OFF when an error is detected
4	ALM-	
-	INP1	Position complete output 1
-	AT-SPEED	Speed complete
-	T_LIM	Torque limit
-	ZSP	Zero speed
-	V-COIN	Speed coincidence
-	INP2	Position complete output 2
-	WARN1	Warning 1
-	WARN2	Warning 2
-	DEN	Origin proximity
-	V_LIM	Speed limit

I/O signals (CN1) - Input signals (for analog/pulse servo drives)

Pin No.	Control mode	Signal name	Function	
1	Position/	+24 VCW	Reference pulse input for line driver and open collector according to parameter setting.  Input mode: Sign + pulse string Reverse/forward pulse (CCW/CW pulse) Two-phase pulse (90° phase differential)	
3	Full close loop	+CW		
4		-CW		
2		+24 VCW		
5		+CCW		
6		-CCW		
44		+CWLD	Reference pulse input for line driver only.	
45		-CWLD		
46		+CCWLD	Input mode: Reverse/forward pulse (CCW/CW pulse)	
47		-CCWLD		
14	Speed	REF	Speed reference input: ±10 V/rated motor speed (input gain can be modified using a parameter).	
	Torque	TREF1	Torque reference input: ±10 V/rated motor torque (input gain can be modified using a parameter).	
		VLIM	Speed limit input: ±10 V/rated motor speed (input gain can be modified using a parameter).	
15	-	AGND1	Analog signal ground	
16	Torque	TREF2	Torque reference input: ±10 V/rated motor torque (input gain can be modified using a parameter).	
	Position/Speed	PCL	Forward torque limit input: ±10 V/rated motor torque (input gain can be modified using a parameter).	
18	Full close loop	NCL	Reverse torque limit input: ±10 V/rated motor torque (input gain can be modified using a parameter).	
17	-	AGND1	Analog signal ground	
7	Common	+24 VIN	Control power supply input for sequence signals: users must provide the +24 V power supply (12 to 24 V).	
29		RUN	Servo ON: this turn ON the servo.	
26	Position/Full close loop	DFSEL1	Vibration filter switching 1	Enables vibration filter according parameter setting.
27	Common	GSEL	Gain switching	Enables gain value according parameter setting.
28	Position/Full close loop	GESEL1	Electronic gear switching 1	Switches the numerator fro electronic gear ratio.
	Speed	VSEL3	Internal speed selection 3	Input to select the desired speed setting during internally speed operation. The speed selecton is combining this input with VSEL1 and VSEL2 inputs.
30	Position/Full close loop	ECRST	Error counter reset input.	Resets the position error counter.
	Speed	VSEL2	Internal speed selection 2	Input to select the desired speed setting during internally speed operation. The speed selecton is combining this input with VSEL1 and VSEL3 inputs.
31	Common	RESET	Alarm reset input.	Release the alarm status. The error counter is reset when the alarm is reset.
32	Position/Speed/Torque	TVSEL	Control mode switching	Position ↔ speed Position ↔ torque Torque ↔ speed } Enables control mode switching
33	Position	IPG	Pulse prohibition input. Digital input to inhibit the position reference pulse.	
	Speed	VSEL1	Internal speed selection 1	Input to select the desired speed setting during internally speed operation. The speed selecton is combining this input with VSEL2 and VSEL3 inputs.
8	Coomon	NOT	Reverse run prohibited	Overtravel prohibited: stops servomotor when movable part travels beyond the allowable range of motion.
9		POT	Forward run prohibited	
20	Position/	SEN	Sensor ON input. Initial data request signal when using an absolute encoder.	
13	Speed/Torque	SENGND	Sensor ON signal ground.	
42	Common	BAT (+)	Backup battery connection terminals when the absolute encoder power is interrupted. Do not connect when a absolute encoder battery cable for backup is used.	
43		BATGND (-)		
50		FG	Frame ground	
-	-	TLSEL	Torque limit switch	The function of input signals allocated to pins 8,9 and 26 to 33 can be changed with these options by parameters settings
		DFSEL2	Vibration filter switching 2	
		GESEL2	Electronic gear switching 2	
		VZERO	Zero speed	
		VSIGN	Speed command signal	
		TSIGN	Torque command signal	
		E-STOP	Emergency stop	
		JSEL	Inertia ratio switching	
12	-		Terminals not used. Do not connect.	
40	-			
41	-			



I/O signals (CN1) - output signals (for analog/pulse servo drives)

Pin No.	Control mode	Signal name	Function
21	Position/ Full close loop	+A	Encoder phase A+
22		-A	Encoder phase A-
48		+B	Encoder phase B+
49		-B	Encoder phase B-
23		+Z	Encoder phase Z+
24		-Z	Encoder phase Z-
19		Z	Encoder phase-Z output
25	ZCOM	Encoder phase-Z common	Encoder signals (or external scale signals during full closing control) are output according Encoder Dividing Numerator parameter. This is the line-driver output (equivalent to R422). The maximum output frequency is 4 Mbps. Phase Z is output for encoder signals (or external scale signals during full closing control). This is the line-driver output (equivalent to R422).
11	Common	BKIR	Brake release signal output
10		BKIRCOM	Timing signal for operating the electromagnetic brake on a motor.
35		READY	Servo ready: ON if there is not servo alarm when the control/main circuit power supply is turned ON.
34		READYCOM	
37		/ALM	Servo alarm: turns OFF when an error is detected.
36		ALMCOM	
39	Speed/torque	TGON	Motor rotation speed detection. This output turns ON when the motor rotation speed reaches the speed set in a parameter.
39	Position/ Full close loop	INP1	Positioning complete output 1: turns ON when position error is equal to setting parameter.
38		INP1COM	
-	-	INP2	Position complete output 2
		P-CMD	Position command status
		ZSP	Zero speed
		WARN1	Warning 1
		WARN2	Warning 2
		ALM-ATB	Alarm output
		VCMP	Speed conformity output
		V-CMD	Speed command status
		V-LIMIT	Speed limit detection
		T-LIMIT	Torque limit detection

Encoder connector (CN2) - (for all servo drives)

Pin No.	Signal name	Function
1	E5V	Encoder power supply + 5 V
2	E0V	Encoder power supply ground
3	BAT+	Battery + (used only with absolute encoder)
4	BAT-	Battery - (used only with absolute encoder)
5	PS+	Encoder serial signal input (+phase)
6	PS-	Encoder serial signal input (-phase)
Shell	FG	Shield ground

External encoder connector (CN4) - (for all servo drives)

Pin No.	Signal name	Function
1	E5V	External scale power supply output. Use at 5.2V +/-5% and at or below 250 mA.
2	E0V	This is connected to the control circuit ground connected to connector CN1.
3	PS	External scale signal I/O (serial signal).
4	/PS	
5	EXA	External scale signal input (Phase A, B, and Z signals). Performs the input and output of phase A, B and Z signals.
6	/EXA	
7	EXB	
8	/EXB	
9	EXZ	
10	/EXZ	
Shell	FG	Shield ground

Monitor connector (CN5) - (for all servo drives)

Pin No.	Signal name	Function
1	AM1	Analog monitor output 1. Outputs the analog signal for the monitor. Use the parameters setting to select the output to monitor. Default setting: Motor rotation speed 1 V/(1000 r/min).
2	AM2	Analog monitor output 2. Outputs the analog signal for the monitor. Use the parameters setting to select the output to monitor. Default setting: Motor rotation speed 1 V/(1000 r/min).
3	GND	Ground for analog monitors 1,2.
4	-	Terminals not used. Do not connect.
5	-	
6	-	

USB connector (CN7) - (all servo drives)

Pin No.	Signal name	Function
1	VBUS	USB signal terminal for computer communication.
2	D-	
3	D+	Ground for analog monitors 1,2.
4	-	Not used. Do not connect.
5	GND	Signal ground.



Safety connector (CN8) - (all servo drives)

Pin No.	Signal name	Function
1	-	Not used. Do not connect.
2	-	
3	SF1-	Safety input 1 & 2. This input turns OFF the power transistor drive signals in the servo drive to cut off the current output to the motor.
4	SF1+	
5	SF2-	
6	SF2+	
7	EDM-	A monitor signal is output to detect a safety function failure.
8	EDM+	
Shell	FG	Frame ground.

Dimensions

Servo drives

R88D-KT01/02H, R88D-KN01/02H-ML2 (230 V, 100 - 200 W)

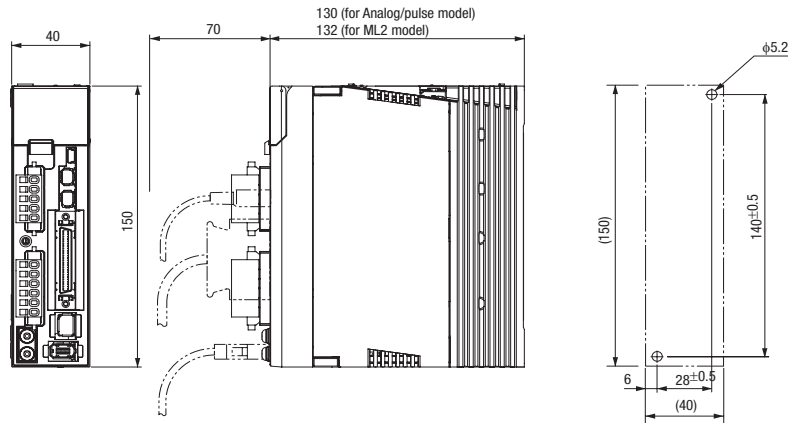

R88D-KT04H, R88D-KN04H-ML2 (230 V, 400 W)

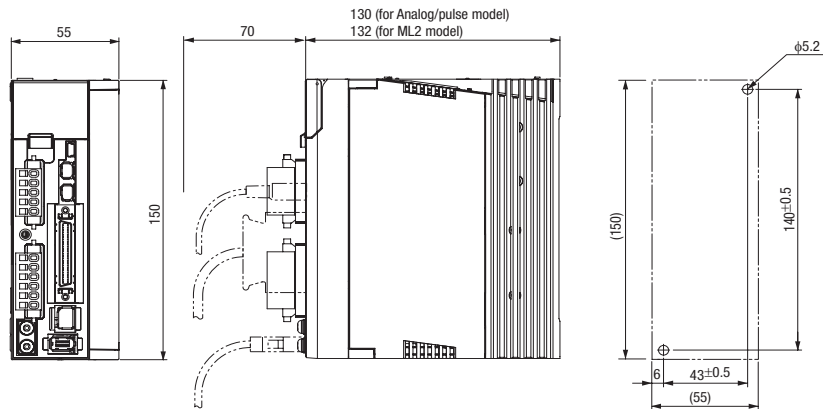

R88D-KT08H, R88D-KN08H-ML2 (230 V, 750 W)

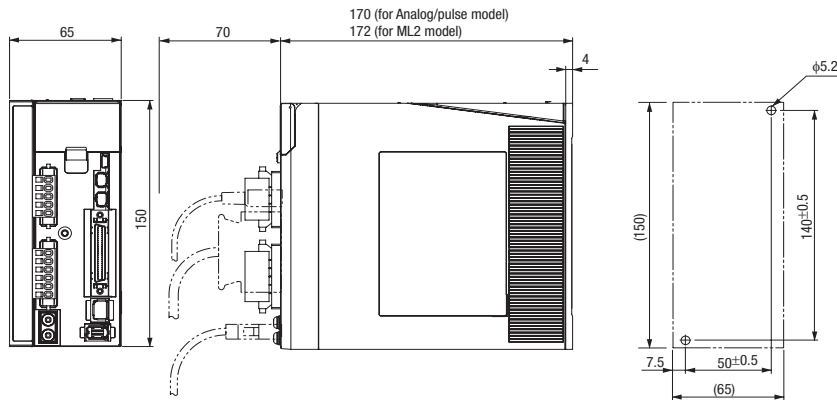

**R88D-KT10/15H, R88D-KN10/15H-ML2 (230 V, 1 - 1.5 kW)**

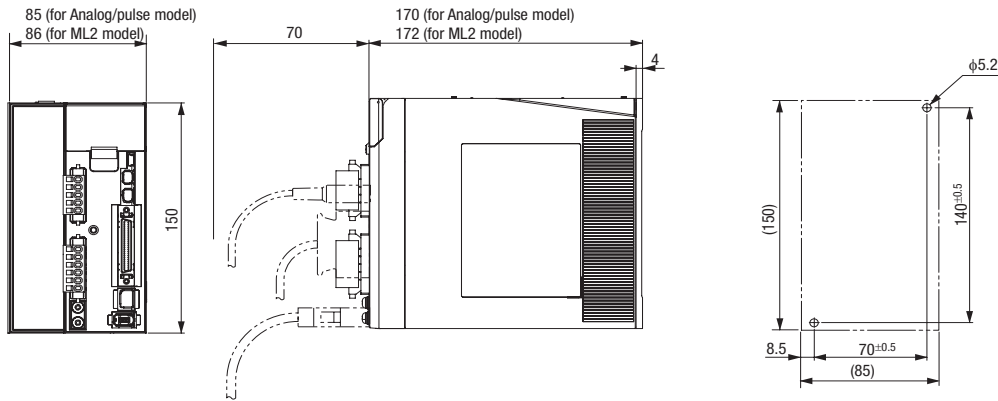

**R88D-KT06/10/15F, R88D-KN06/10/15F-ML2 (400 V, 600 W - 1.5 kW)**

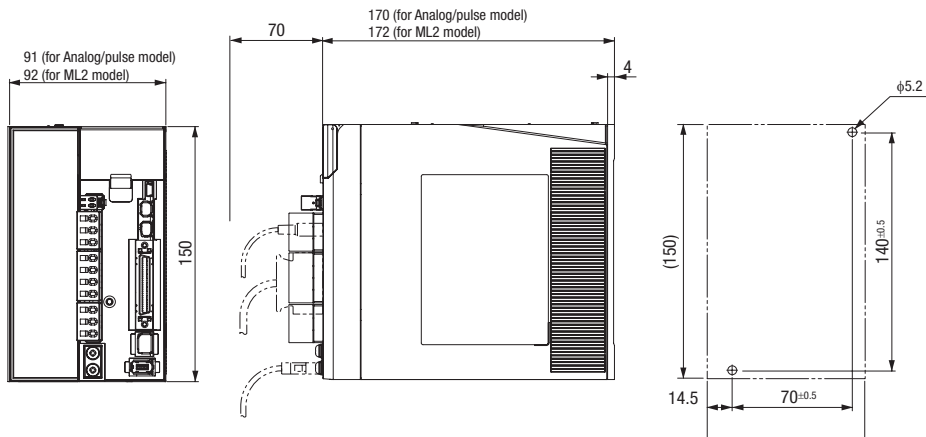

**R88D-KT20F, R88D-KN20F-ML2 (400 V, 2 kW)**

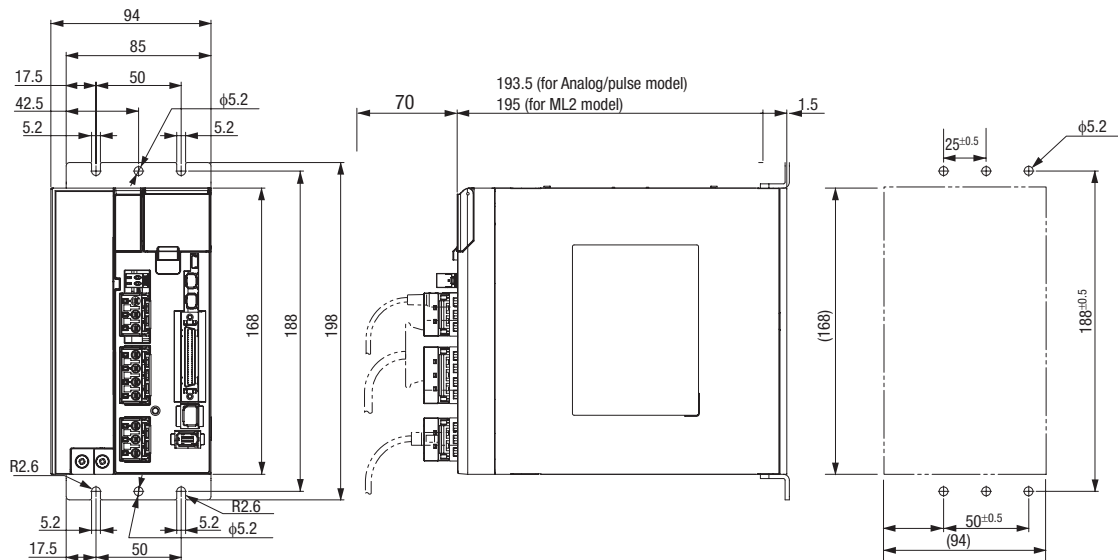

R88D-KT30/50F, R88D-KN30/50F-ML2 (400 V, 3 - 5 kW)

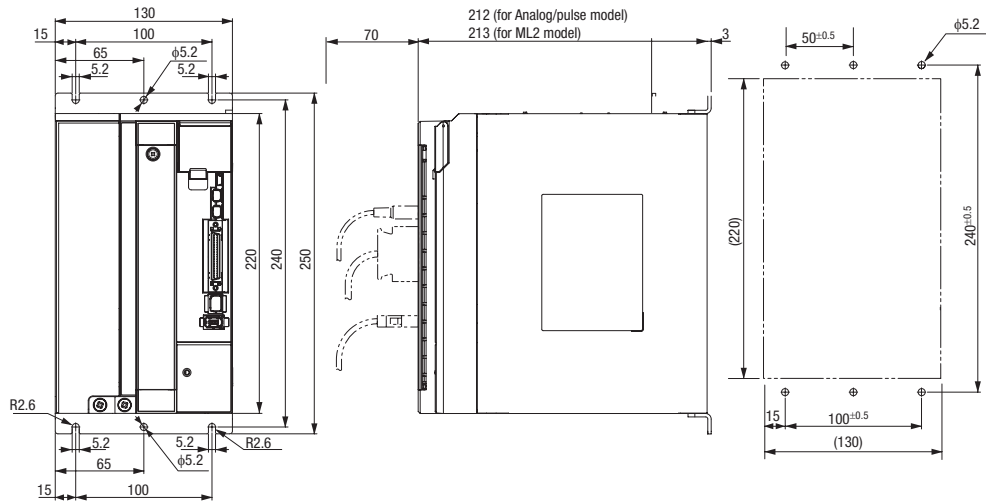

Filters

Filter model	External dimensions			Mount dimensions	
	H	W	D	M1	M2
R88A-FIK102-RE	190	42	44	180	20
R88A-FIK104-RE	190	57	30	180	30
R88A-FIK107-RE	190	64	35	180	40
R88A-FIK114-RE	190	86	35	180	60
R88A-FIK304-RE	190	86	40	180	60
R88A-FIK306-RE	245	94	40	235	60
R88A-FIK312-RE	290	130	45	280	100

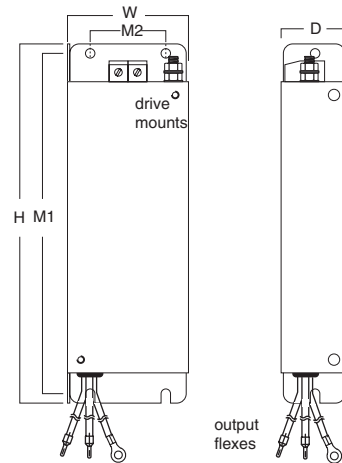

Installation

Single-phase, 230 VAC (for MECHATROLINK-II servo drives)

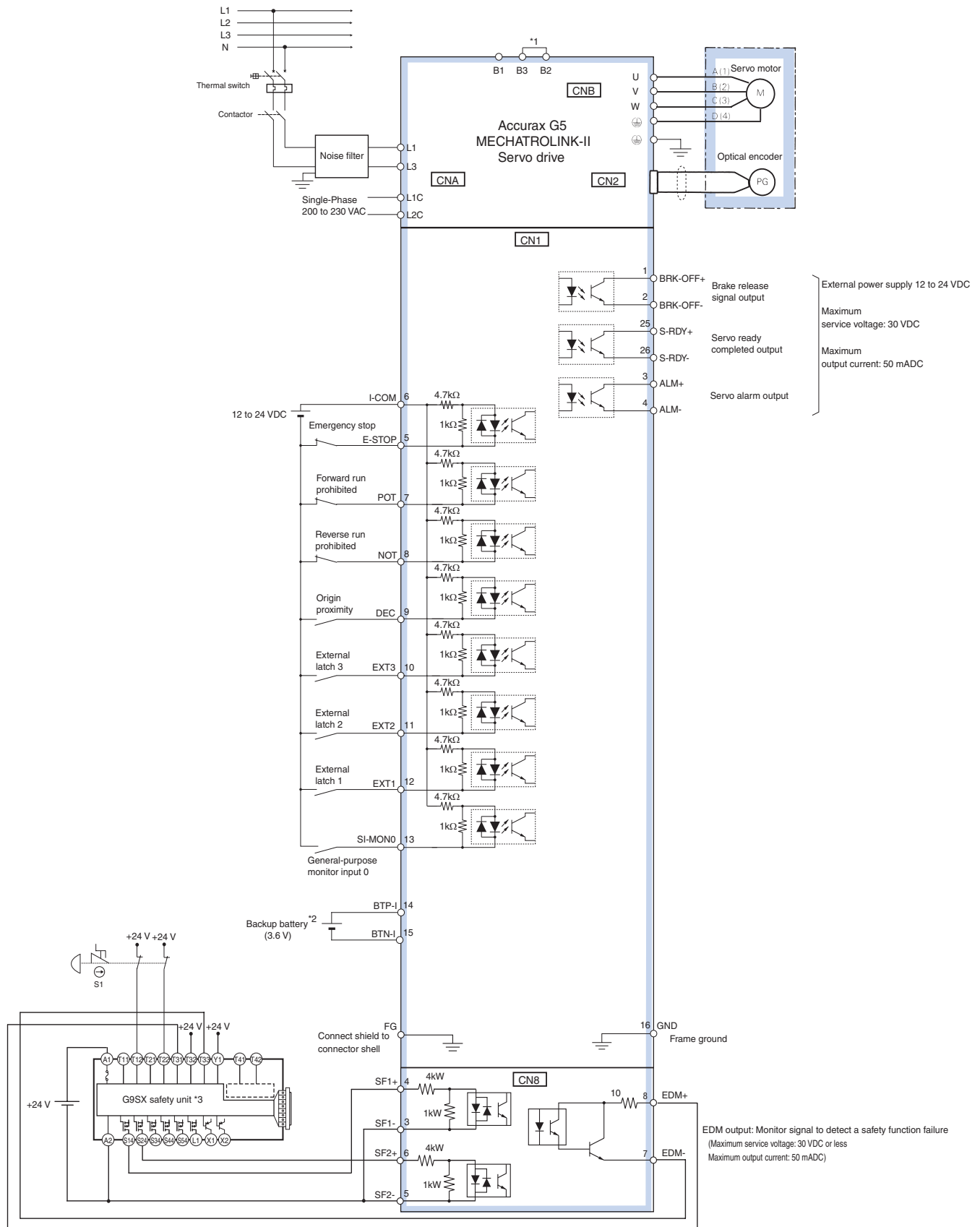

\*1 For servo drives from 750 W, B2 and B3 are short-circuited. If the internal regenerative resistor is insufficient, remove the wire between B2 and B3 and connect an external regenerative resistor between B1 and B2.

\*2 For use only with an absolute encoder. If a backup battery is connected to CN1 I/O connector, an encoder cable with a battery is not required.

\*3 Wiring diagram example using the G9SX safety unit. If a safety unit is not used, keep the factory safety bypass connector installed in the CN8.

**Note:** The input function of pins 5 and 7 to 13, and output function of pins 1, 2, 25 and 26, can be changed via parameter settings.

Three-phase, 400 VAC (for MECHATROLINK-II servo drives)

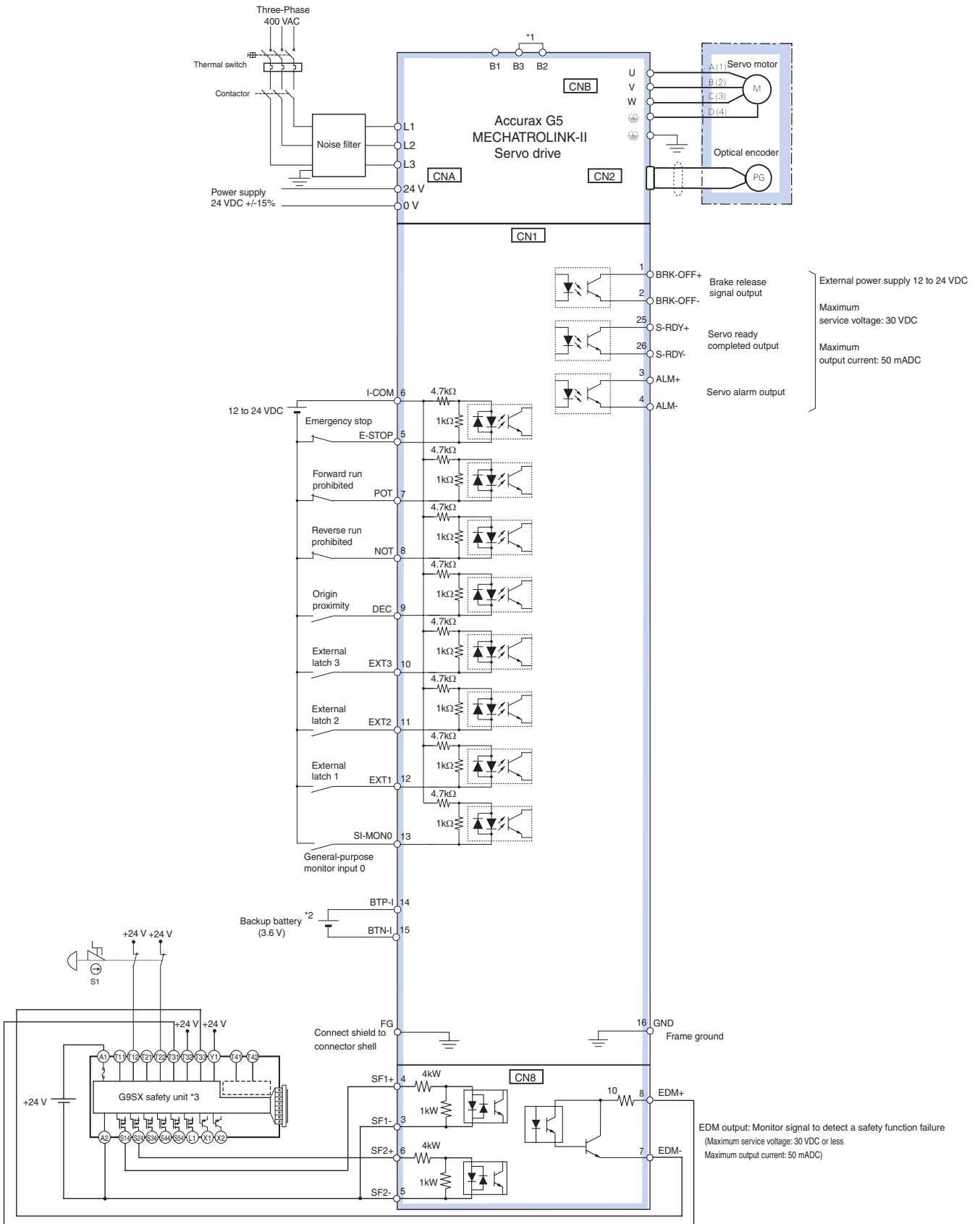

\*1 Normally B2 and B3 are short-circuited. If the internal regenerative resistor is insufficient, remove the wire between B2 and B3 and connect an external regenerative resistor between B1 and B2.

\*2 For use only with an absolute encoder. If a backup battery is connected to CN1 I/O connector, an encoder cable with a battery is not required.

\*3 Wiring diagram example using the G9SX safety unit. If a safety unit is not used, keep the factory safety bypass connector installed in the CN8.

**Note:** The input function of pins 5 and 7 to 13, and output function of pins 1, 2, 25 and 26, can be changed via parameter settings.

Single-phase, 230 VAC(for analog/pulse servo drives)

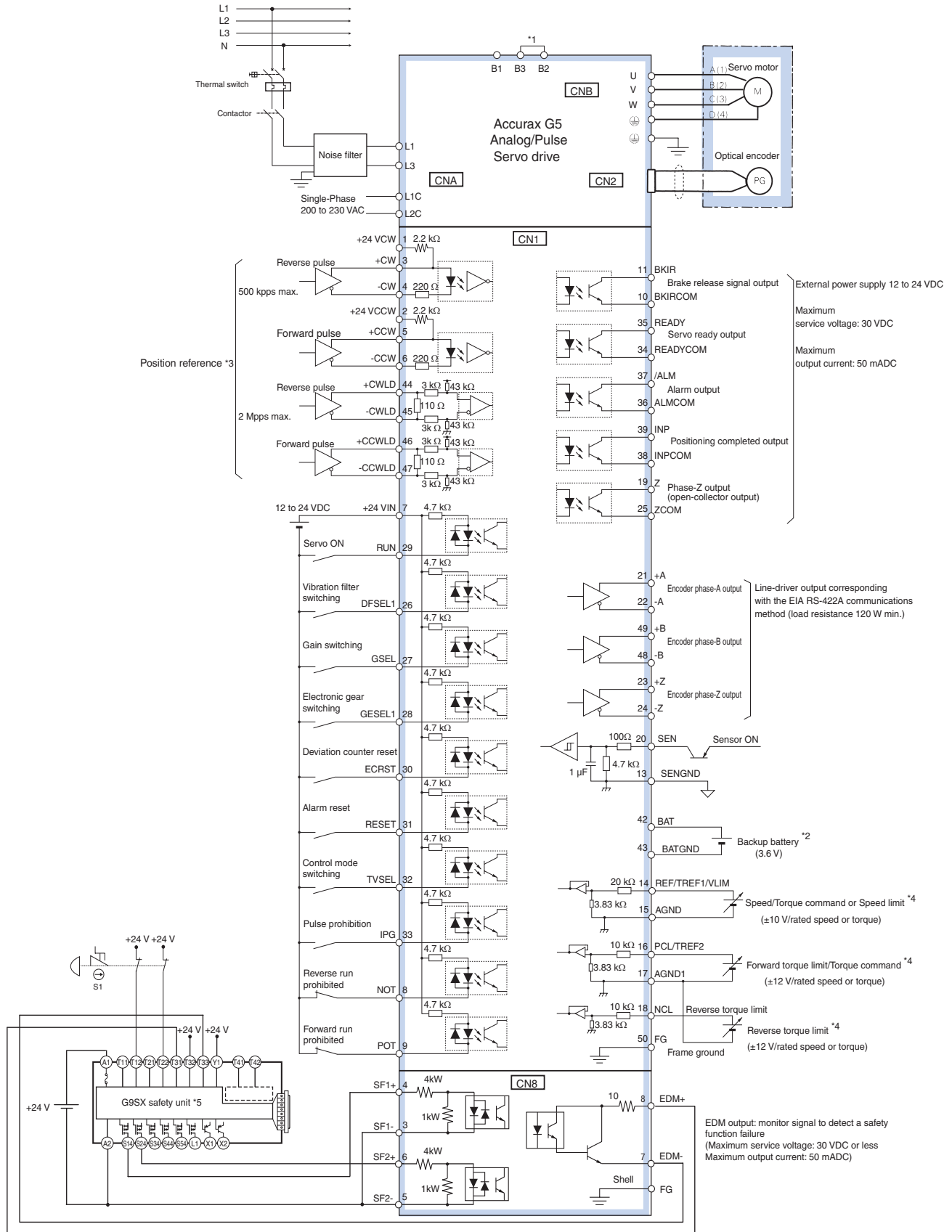

\*1 For servo drives from 750 W, B2 and B3 are short-circuited. If the internal regenerative resistor is insufficient, remove the wire between B2 and B3 and connect an external regenerative resistor between B1 and B2.  
 \*2 For use only with an absolute encoder. If a backup battery is connected to CN1 I/O connector, an encoder cable with a battery is not required.  
 \*3 Only available in Position control mode.  
 \*4 The input function depends on control mode used (Position, speed or torque control).  
 \*5 Wiring diagram example using the G9SX safety unit. If a safety unit is not used, keep the factory safety bypass connector installed in the CN8.

**Note:** The input function of pins 8,9 and 26 to 33, and output function of pins 10, 11, 34, 35, 38 and 39, can be changed via parameter settings.

Three-phase, 400 VAC (for analog/pulse servo drives)

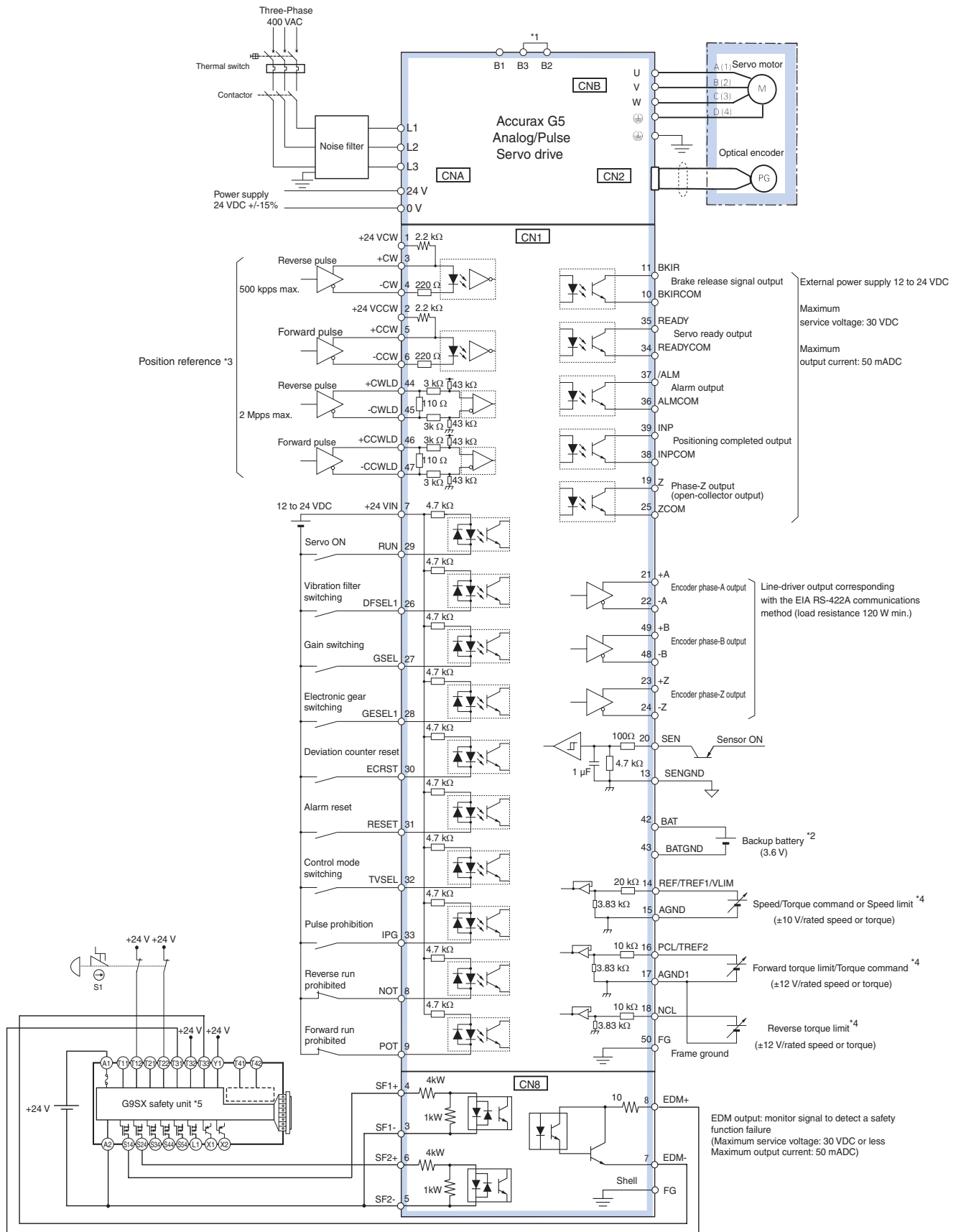

\*1 Normally B2 and B3 are short-circuited. If the internal regenerative resistor is insufficient, remove the wire between B2 and B3 and connect an external regenerative resistor between B1 and B2.  
 \*2 For use only with an absolute encoder. If a backup battery is connected to CN1 I/O connector, an encoder cable with a battery is not required.  
 \*3 Only available in Position control mode.  
 \*4 The input function depends on control mode used (Position, speed or torque control).  
 \*5 Wiring diagram example using the G9SX safety unit. If a safety unit is not used, keep the factory safety bypass connector installed in the CN8.

**Note:** The input function of pins 8,9 and 26 to 33, and output function of pins 10, 11, 34, 35, 38 and 39, can be changed via parameter settings.

AC Servo systems



Ordering information

Accurax G5 series MECHATROLINK-II reference configuration

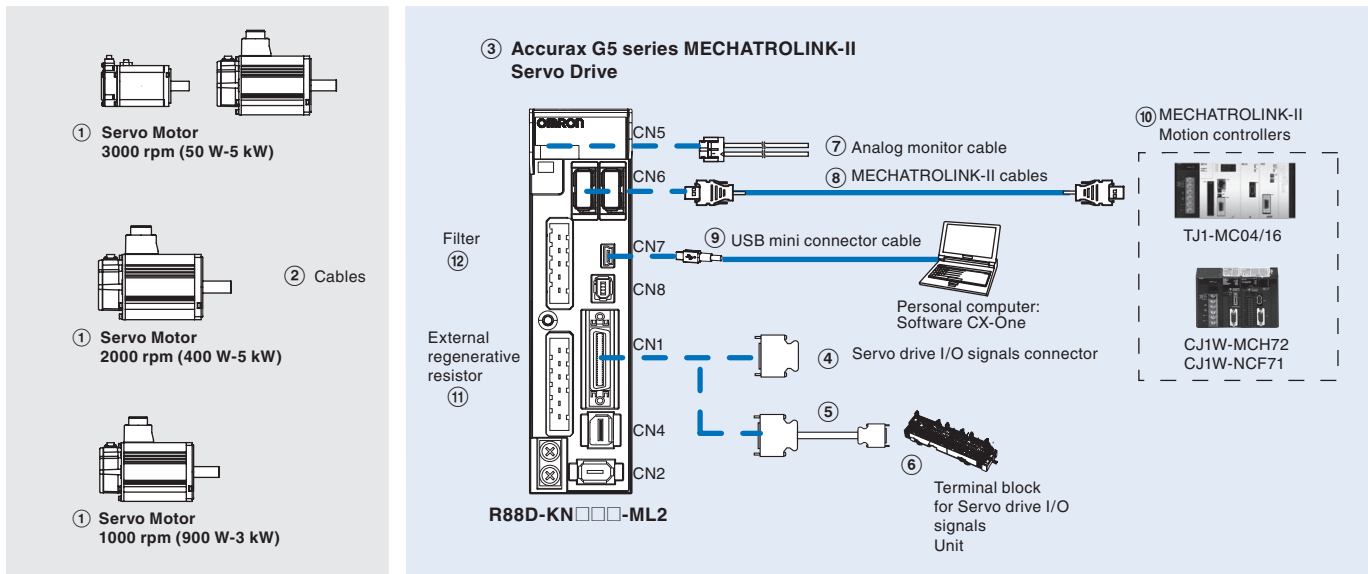

Note: The symbols ①②③④⑤... show the recommended sequence to select the components in Accurax G5 servo system

Servo motors, power & encoder cables

Note: ①② Refer to the Accurax G5 servo motor chapter for servomotor, motor cables or connectors selection

Servo drives

Symbol	Specifications		Servo drive model	① Compatible G5 series rotary servo motors	
③	1 phase 230 VAC	100 W	R88D-KN01H-ML2	R88M-K05030(H/T)-□ R88M-K10030(H/T)-□	
		200 W	R88D-KN02H-ML2	R88M-K20030(H/T)-□	
		400 W	R88D-KN04H-ML2	R88M-K40030(H/T)-□	
		750 W	R88D-KN08H-ML2	R88M-K75030(H/T)-□	
		1.0 kW	R88D-KN10H-ML2	R88M-K1K020(H/T)-□ R88M-K1K530(H/T)-□ R88M-K1K520(H/T)-□	
		1.5 kW	R88D-KN15H-ML2	R88M-K90010(H/T)-□ R88M-K40020(F/C)-□ R88M-K60020(F/C)-□	
		3 phase 400 VAC	600 W	R88D-KN06F-ML2	R88M-K75030(F/C)-□ R88M-K1K020(F/C)-□
			1.0 kW	R88D-KN10F-ML2	R88M-K1K030(F/C)-□ R88M-K1K530(F/C)-□ R88M-K1K520(F/C)-□ R88M-K90010(F/C)-□
			1.5 kW	R88D-KN15F-ML2	R88M-K2K030(F/C)-□ R88M-K2K020(F/C)-□
	2.0 kW		R88D-KN20F-ML2	R88M-K3K030(F/C)-□ R88M-K3K020(F/C)-□ R88M-K2K010(F/C)-□	
	3.0 kW		R88D-KN30F-ML2	R88M-K4K030(F/C)-□ R88M-K5K030(F/C)-□ R88M-K4K020(F/C)-□ R88M-K5K020(F/C)-□	
	5.0 kW		R88D-KN50F-ML2	R88M-K3K010(F/C)-□	

**Control cables (for CN1)**

Symbol	Description	Connect to	Model
④	I/O connector kit (26 pins)	For I/O general purpose	- R88A-CNW01C
	General purpose cable		1 m R88A-CPKB001S-E
⑤	Terminal block cable	For I/O general purpose	1 m XW2Z-100J-B34
			2 m XW2Z-200J-B34
⑥	Terminal block (M3 screw and for pin terminals)	-	XW2B-20G4
	Terminal block (M3.5 screw and for fork/round terminals)	-	XW2B-20G5
	Terminal block (M3 screw and for fork/round terminals)	-	XW2D-20G6

**Analog monitor (for CN5)**

Symbol	Name	Length	Model
⑦	Analog monitor cable	1m	R88A-CMK001S

**MECHATROLINK-II cables (for CN6)**

Symbol	Specifications	Length	Model
⑧	MECHATROLINK-II Terminator resistor	-	JEPMC-W6022-E
	MECHATROLINK-II cables	0.5 m	JEPMC-W6003-A5-E
		1 m	JEPMC-W6003-01-E
		3 m	JEPMC-W6003-03-E
		5 m	JEPMC-W6003-05-E
		10 m	JEPMC-W6003-10-E
		20 m	JEPMC-W6003-20-E
30 m	JEPMC-W6003-30-E		

**USB personal computer cable (for CN7)**

Symbol	Name	Length	Model
⑨	USB mini-connector cable	2m	AX-CUSBM002-E

**MECHATROLINK-II Motion controllers**

Symbol	Name	Model
⑩	Trajexia stand-alone motion controller	TJ1-MC04 (4 axes)
		TJ1-MC16 (16 axes)
	Trajexia-PLC motion controller	CJ1W-MCH72
	Position Controller Unit for CJ1 PLC	CJ1W-NCF71 (16 axes)
		CJ1W-NC471 (4 axes)
	Position Controller Unit for CS1 PLC	CJ1W-NC271 (2 axes)
CS1W-NCF71 (16 axes)		
		CS1W-NC471 (4 axes)
		CS1W-NC271 (2 axes)

**External regenerative resistor**

Symbol	Regenerative resistor unit model	Specifications
⑪	R88A-RR08050S	50 Ω, 80 W
	R88A-RR080100S	100 Ω, 80 W
	R88A-RR22047S	47 Ω, 220 W
	R88A-RR50020S	20 Ω, 500 W

**Cable for Safety Functions (for CN8)**

Symbol	Description	Model
-	Safety connector with 3 m cable (with loose wires at one end)	R88A-CSK003S-E

**Filters**

Symbol	Applicable servodrive	Filter model	Rated current	Leakage current	Rated voltage
⑫	R88D-KN01H-ML2, R88D-KN02H-ML2	R88A-FIK102-RE	2.4 A	3.5 mA	250 VAC single-phase
	R88D-KN04H-ML2	R88A-FIK104-RE	4.1 A	3.5 mA	
	R88D-KN08H-ML2	R88A-FIK107-RE	6.6 A	3.5 mA	
	R88D-KN10H-ML2, R88D-KN15H-ML2	R88A-FIK114-RE	14.2 A	3.5 mA	400 VAC three-phase
	R88D-KN06F-ML2, R88D-KN10F-ML2, R88D-KN15F-ML2	R88A-FIK304-RE	4 A	0.3 mA / 32 mA <sup>1</sup>	
	R88D-KN20F-ML2	R88A-FIK306-RE	6 A	0.3 mA / 32 mA <sup>1</sup>	
	R88D-KN30F-ML2, R88D-KN50F-ML2	R88A-FIK312-RE	12.1 A	0.3 mA / 32 mA <sup>1</sup>	

1. Momentary peak leakage current for the filter at switch-on/off.

**Connectors**

Specifications	Model
External encoder connector (for CN4)	R88A-CNK41L
Safety I/O signal connector (for CN8)	R88A-CNK81S

**Computer software**

Specifications	Model
Configuration and monitoring software tool for servo drives and inverters. (CX-drive version 1.91 or higher)	CX-drive

Ordering information

Accurax G5 series Analog/pulse Reference configuration

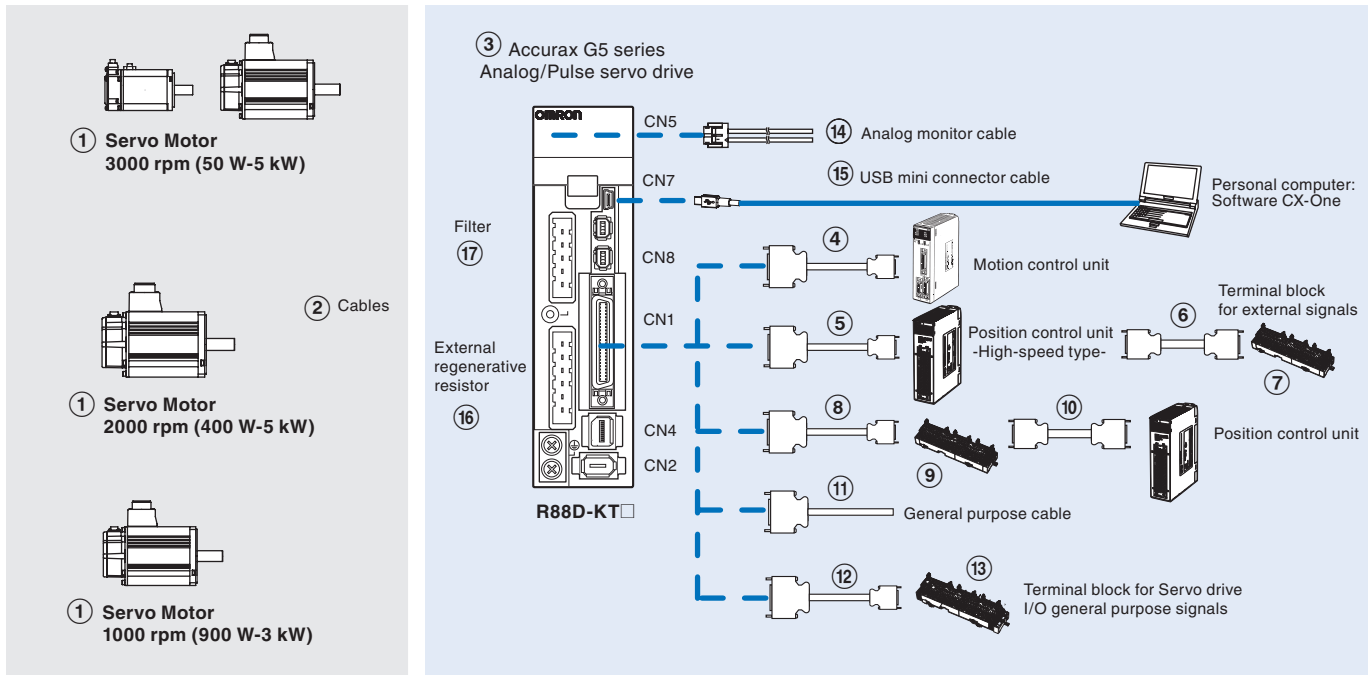

Note: The symbols ①②③④⑤... show the recommended sequence to select the components in Accurax G5 servo system

Servo motors, power & encoder cables

Note: ①② Refer to the Accurax G5 servo motor chapter for servomotor, motor cables or connectors selection

Servo drives

Symbol	Specifications		Servo drive model	① Compatible Accurax G5 series rotary servo motors		
③	1 phase 230 VAC	100 W	R88D-KT01H	R88M-K05030(H/T)-□ R88M-K10030(H/T)-□		
		200 W	R88D-KT02H	R88M-K20030(H/T)-□		
		400 W	R88D-KT04H	R88M-K40030(H/T)-□		
		750 W	R88D-KT08H	R88M-K75030(H/T)-□		
		1.0 kW	R88D-KT10H	R88M-K1K020(H/T)-□		
		1.5 kW	R88D-KT15H	R88M-K1K030(H/T)-□		
				R88M-K1K530(H/T)-□		
				R88M-K1K520(H/T)-□		
				R88M-K90010(H/T)-□		
	3 phase 400 VAC			600 W	R88D-KT06F	R88M-K40020(F/C)-□ R88M-K60020(F/C)-□
				1.0 kW	R88D-KT10F	R88M-K75030(F/C)-□ R88M-K1K020(F/C)-□
		1.5 kW	R88D-KT15F	R88M-K1K030(F/C)-□		
	R88M-K1K530(F/C)-□					
	R88M-K1K520(F/C)-□					
	R88M-K90010(F/C)-□					
	2.0 kW	R88D-KT20F	R88M-K2K030(F/C)-□ R88M-K2K020(F/C)-□			
	3.0 kW	R88D-KT30F	R88M-K3K030(F/C)-□			
			R88M-K3K020(F/C)-□			
			R88M-K2K010(F/C)-□			
	5.0 kW	R88D-KT50F	R88M-K4K030(F/C)-□			
			R88M-K5K030(F/C)-□			
R88M-K4K020(F/C)-□						
R88M-K5K020(F/C)-□						
R88M-K3K010(F/C)-□						

Control cables (for CN1)

Symbol	Description	Connect to		Model	
④	Control cable (1 axis)	Motion control units CS1W-MC221 CS1W-MC421	1 m	R88A-CPG001M1	
			2 m	R88A-CPG002M1	
			3 m	R88A-CPG003M1	
	Control cable (2 axis)	Motion control units CS1W-MC221 CS1W-MC421	1 m	R88A-CPG001M2	
			2 m	R88A-CPG002M2	
			3 m	R88A-CPG003M2	
⑤	Control cable (line-driver output for 1 axis)	Position control units (high-speed type) CJ1W-NC234 CJ1W-NC434	1 m	XW2Z-100J-G9	
			5 m	XW2Z-500J-G9	
			10 m	XW2Z-10MJ-G9	
	Control cable (open-collector output for 1 axis)	Position control units (high-speed type) CJ1W-NC214 CJ1W-NC414	1 m	XW2Z-100J-G13	
			3 m	XW2Z-300J-G13	
	Control cable (line-driver output for 2 axis)	Position control units (high-speed type) CJ1W-NC234 CJ1W-NC434	1 m	XW2Z-100J-G1	
			5 m	XW2Z-500J-G1	
	Control cable (open-collector output for 2 axis)	Position control units (high-speed type) CJ1W-NC214 CJ1W-NC414	1 m	XW2Z-100J-G5	
			3 m	XW2Z-300J-G5	
	⑥	Terminal block cable for external signals (for input common, forward/reverse run prohibited inputs, emergency stop input, origin proximity input and interrupt input)	Position control units (high-speed type) CJ1W-NC234 CJ1W-NC434 CJ1W-NC214 CJ1W-NC414	0.5 m	XW2Z-C50X
				1 m	XW2Z-100X
				2 m	XW2Z-200X
3 m				XW2Z-300X	
5 m				XW2Z-500X	
10 m				XW2Z-010X	
-				XW2B-20G4	
⑦	Terminal block for external signals (M3 screw, pin terminals)	-	XW2B-20G5		
	Terminal block for ext. signals (M3.5 screw, fork/round terminals)	-	XW2D-20G6		
	Terminal block for ext. signals (M3 screw, fork/round terminals)	-			
⑧	Cable from servo relay unit to servo drive	CS1W-NC1□3, CJ1W-NC1□3, C200HW-NC113, CS1W-NC2□3/4□3, CJ1W-NC2□3/4□3, C200HW-NC213/413, CQM1H-PLB21 or CQM1-CPU43 CJ1M-CPU21/22/23	1 m	XW2Z-100J-B25	
			2 m	XW2Z-200J-B25	
			1 m	XW2Z-100J-B31	
			2 m	XW2Z-200J-B31	
⑨	Servo relay unit	Position control units CS1W-NC1□3, CJ1W-NC1□3 or C200HW-NC113 Position control units CS1W-NC2□3/4□3, CJ1W-NC2□3/4□3 or C200HW-NC213/413 CQM1H-PLB21 or CQM1-CPU43 CJ1M-CPU21/22/23	-	XW2B-20J6-1B (1 axis)	
			-	XW2B-40J6-2B (2 axes)	
			-	XW2B-20J6-3B (1 axis)	
			-	XW2B-20J6-8A (1 axis) XW2B-40J6-9A (2 axes)	
			-		
⑩	Position control unit connecting cable	CQM1H-PLB21 CS1W-NC113 or C200HW-NC113 CS1W-NC213/413 or C200HW-NC213/413 CS1W-NC133 CS1W-NC233/433 CJ1W-NC113 CJ1W-NC213/413 CJ1W-NC133 CJ1W-NC233/433 CJ1M-CPU21/22/23	0.5 m	XW2Z-050J-A3	
			1 m	XW2Z-100J-A3	
			0.5 m	XW2Z-050J-A6	
			1 m	XW2Z-100J-A6	
			0.5 m	XW2Z-050J-A7	
			1 m	XW2Z-100J-A7	
			0.5 m	XW2Z-050J-A10	
			1 m	XW2Z-100J-A10	
			0.5 m	XW2Z-050J-A11	
			1 m	XW2Z-100J-A11	
			0.5 m	XW2Z-050J-A14	
			1 m	XW2Z-100J-A14	
			0.5 m	XW2Z-050J-A15	
			1 m	XW2Z-100J-A15	
			0.5 m	XW2Z-050J-A18	
			1 m	XW2Z-100J-A18	
0.5 m	XW2Z-050J-A19				
1 m	XW2Z-100J-A19				
0.5 m	XW2Z-050J-A33				
1 m	XW2Z-100J-A33				
⑪	General purpose cable	For general purpose controllers	1 m	R88A-CPG001S	
			2 m	R88A-CPG002S	
⑫	Terminal block cable	For general purpose controllers	1 m	XW2Z-100J-B24	
			2 m	XW2Z-200J-B24	
⑬	Terminal block (M3 screw and for pin terminals)	-	XW2B-50G4		
	Terminal block (M3.5 screw and for fork/round terminals)	-	XW2B-50G5		
	Terminal block (M3 screw and for fork/round terminals)	-	XW2D-50G6		

## Analog monitor (for CN5)

Symbol	Name		Model
⑭	Analog monitor cable	1m	R88A-CMK001S

## USB personal computer cable (for CN7)

Symbol	Name		Model
⑮	USB mini-connector cable	2m	AX-CUSBM002-E

## External regenerative resistor

Symbol	Regenerative resistor unit model	Specifications
⑯	R88A-RR08050S	50 Ω, 80 W
	R88A-RR080100S	100 Ω, 80 W
	R88A-RR22047S	47 Ω, 220 W
	R88A-RR50020S	20 Ω, 500 W

## Cable for Safety Functions (for CN8)

Symbol	Description	Model
-	Safety connector with 3 m cable (with loose wires at one end)	R88A-CSK003S-E

## Filters

Symbol	Applicable servodrive	Filter model	Rated current	Leakage current	Rated voltage
⑰	R88D-KT01H, R88D-KT02H	R88A-FIK102-RE	2.4 A	3.5 mA	250 VAC single-phase
	R88D-KT04H	R88A-FIK104-RE	4.1 A	3.5 mA	
	R88D-KT08H	R88A-FIK107-RE	6.6 A	3.5 mA	
	R88D-KT10H, R88D-KT15H	R88A-FIK114-RE	14.2 A	3.5 mA	400 VAC three-phase
	R88D-KT06F, R88D-KT10F, R88D-KT15F	R88A-FIK304-RE	4 A	0.3 mA / 32 mA <sup>1</sup>	
	R88D-KT20F	R88A-FIK306-RE	6 A	0.3 mA / 32 mA <sup>1</sup>	
	R88D-KT30F, R88D-KT50F	R88A-FIK312-RE	12.1 A	0.3 mA / 32 mA <sup>1</sup>	

1. Momentary peak leakage current for the filter at switch-on/off.

## Connectors

Specifications	Model
I/O connector kit -50 pins-(for CN1)	R88A-CNU11C
External encoder connector (for CN4)	R88A-CNK41L
Safety I/O signal connector (for CN8)	R88A-CNK81S

## Computer software

Specifications	Model
Configuration and monitoring software tool for servo drives and inverters. (CX-drive version 1.90 or higher)	CX-drive

ALL DIMENSIONS SHOWN ARE IN MILLIMETERS.  
To convert millimeters into inches, multiply by 0.03937. To convert grams into ounces, multiply by 0.03527.