

SPCcompact
Strip Position Controller

EMG Automation GmbH
Industriestraße 1
57482 Wenden / Germany
Telefon: +49 (0) 27 62 / 6 12-0
Telefax: +49 (0) 27 62 / 6 12-3 84
Internet: www.emg-automation.com
E-Mail: servo@emg-automation.com

elexis Unternehmensgruppe

Concise data sheet

Function:	Compact strip position controller
Mechanical design:	Steel sheet housing 200x300x150mm
Connection:	Internal: plug-type block terminals external: cable gland
Weight:	approx. 8kg

Application

SPCcompact is a digital strip position controller for evaluating the stationary EMG sensory system and for activating hydraulic and electrical servo actuators. Adjustment and display of the actual values of the control system is carried out using the ECU01 display and operating unit installed in the front door. Programming of the control functions is made using the EMG projecting and diagnostic software *Logicad32*.

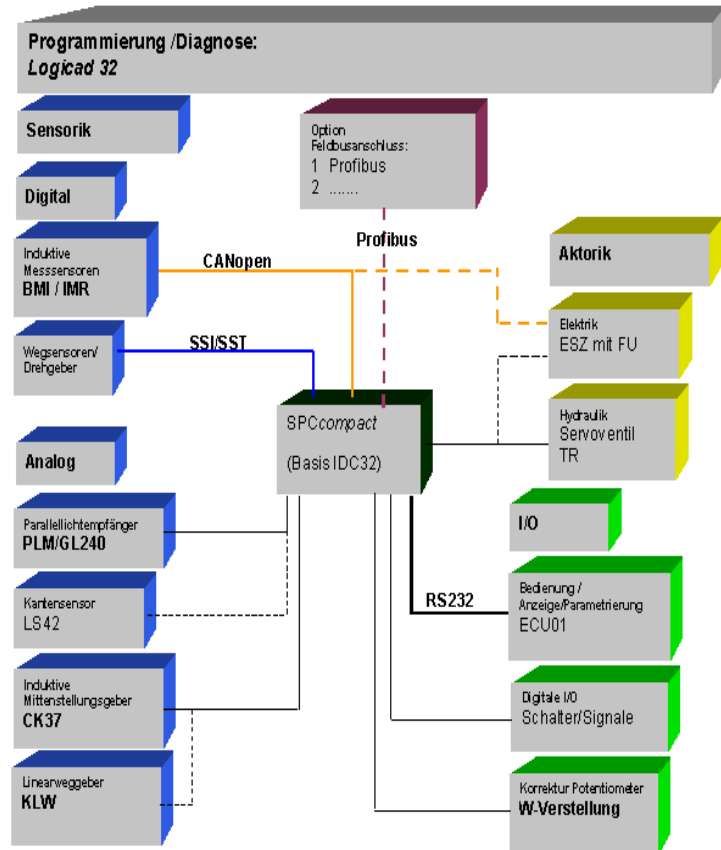

Block diagram

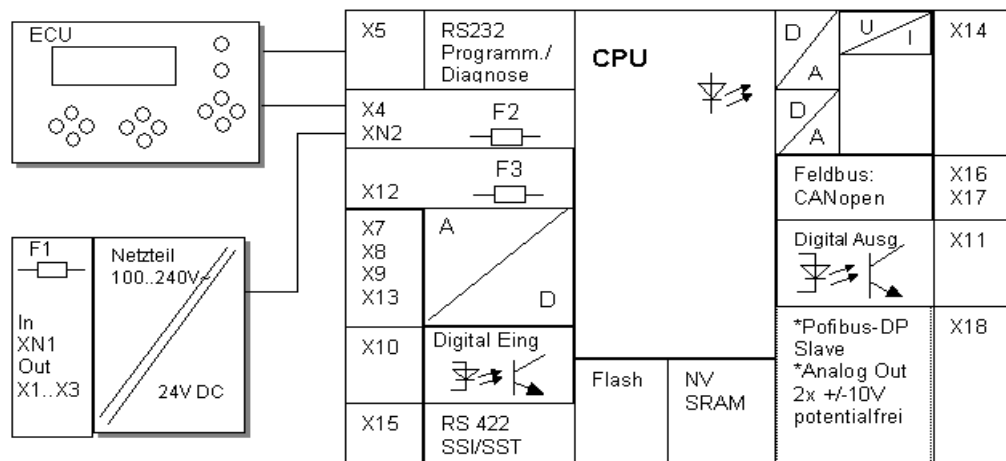

Technical data

Voltage input		
Mains supply	XN1	100...240V AC –15% +10% (F1/1,6AT)
Voltage output	X1...X3	Mains supply additional equipment L1, N, PE max. 200VA
Motherboard	XN2	24V ±10%, 0,2A +Last (F2/1,6AT)
Voltage output	X4	24V ±10%; (supply ECU01)
Diagnostic/programming interface	X5	RS232; D-Sub 9
4 analogue inputs	X7, X8, X9, X13	±5V, ±10V, 0 (4...20) mA, (12 bit) supply: 24V, GND
1st option voltage supply	X7E, X8E	supply: ±15V/100mA, GND
8 digital inputs	X10	+24V (15..30V)/10mA/input potential-free
8 digital outputs	X11	+24V (18..36V external) max. 25mA/ output potential-free
1 Voltage output	X12	24V ±10%; 2A (F3/1,6AT)
1 analogue power output	X14	±0,2/±0,3/±0,66/±1A servovalve (12 bit)
1 analogue voltage output	X14	±10V/5mA (12 bit)
1 digital sensor input	X15	RS422 protocol: alternative SSI; SST
Field bus CANopen	X16/X17	CAN ISO 11898; protocol: CANopen DS301
*2nd option: 2nd field bus interface	X18	Profibus DP (planned: Ethernet; CANopen)
*2nd option: analogue output	X18	2x ±10V/10mA (12 bit) potential-free
Temperature range	0 ... 50°C	
IP protection	IP54	

* Only one of the two 2nd options proposed can be adopted

Type code

SPCc 2. x x x . x

