

The invisible hand for more convenient world

Autonics sensors & controllers

Autonics
Sensors & Controllers

Digital Thyristor Unit

DPU Series

USER MANUAL

CE



Thank you very much for selecting Autonics products.

For your Safety, please read the following before using.

Preface

Thank you for purchasing Autonics product.





Please familiarize yourself with the information contained in the Safety Precautions section before using this product.

This user manual contains information about the product and its proper use, and should be kept in a place where it will be easy to access.

User Manual Guide

- Please familiarize yourself with the information in this manual before using the product.
- This manual provides detailed information on the product's features. It does not offer any guarantee concerning matters beyond the scope of this manual.
- This manual may not be edited or reproduced in either part or whole without permission.
- A user manual is not provided as part of the product package.
- Visit our web site (www.autonics.com) to download a copy.
- The manual's content may vary depending on changes to the product's software and other unforeseen developments within Autonics, and is subject to change without prior notice. Upgrade notice is provided through out homepage.
- We contrived to describe this manual more easily and correctly. However, if there are any corrections or questions, please notify us these on our homepage.

User Manual Symbols

Symbol	Description
 Note	Supplementary information for a particular feature.
 Warning	Failure to follow instructions can result in serious injury or death.
 Caution	Failure to follow instructions can lead to a minor injury or product damage.
 Ex.	An example of the concerned feature's use.
※1	Annotation mark.

Safety Precautions

- Following these safety precautions will ensure the safe and proper use of the product and help prevent accidents and minimize hazards.
- Safety precautions are categorized as Warnings and Cautions, as defined below:

 Warning	Warning	Cases that may cause serious injury or fatal accident if instructions are not followed.
--	----------------	---

 Caution	Caution	Cases that may cause minor injury or product damage if instructions are not followed.
--	----------------	---



Warning

- **Caution for wiring**
If malfunction or error of this unit cause serious accident, install the external protection circuit properly.
This unit does not have power switch. Please install an external power switch.
To prevent electric shock, ground it 1st grounding and supply an electric current to this unit.
- **Power**
To prevent damage or malfunction of this unit, supply the rated power to this unit.
To prevent electric shock and malfunction of this unit, do not supply the power before completing wiring.
- **Ban for using in gas**
It is not an explosion structure. Do not use this unit where there are flammable or explosive gases.
- **Connections**
Do not disassemble or modify this unit. It may cause malfunction, electric shock, or a fire.
Do not touch the terminals during power ON. It may cause malfunction, or electric shock.
- **Caution for maintenance**
Turn OFF the power before removing this unit. It may cause electric shock, cause malfunction, damage to this unit or electric shock.
To use this unit safely, it is recommended to maintain this unit regularly.
Only for proper usage, the term of guarantee for this unit with accessories is 1 year.



Caution

- **Caution for usage (Do not install this unit at the following places.)**
The place where ambient temperature is over -10 to 50°C range.
The place where ambient humidity is over 5 to 90%RH.
The place where temperature changes are rapid and there is dew condensation.
The place where there is corrosive gas (especially oil gas, ammonia, etc), or flammable gas.
The place where there is vibration or shock to the unit.
The place where there is water, oil, drug, or steam.
The place where there is lots of dust and dirt, salinity, or iron.
The place where big inducement malfunction, static, or magnetism noise occurs easily.
The place where there is direct ray of the sun.
The place where thermal heat builds up by radiant heat.
Do not open the cover automatically to move this unit.

- Installations
 - Tighten this unit with bolts as accessories on the panel.
 - If water enters this unit, you must inspect this unit. It may cause short circuit, or a fire.
 - When installing this unit, use safety protections such as safety shoes, and helmet, etc and be sure that the safety.
 - Be sure that not to put the legs or sit on this unit.
- Temporary storage
 - Fix this unit with transportation screws to store this unit temporarily.
 - Store this unit as below environments.
 - The place where there is no dregs, flammable gas, explosive gas (SO₂, H₂SO₄, etc).
 - The place where there is no vibration, shock
 - The place where there is no steam or not too much hot humidity (95%RH)
 - The place where it is not extreme low temperature (below -20°C)
- Caution for wiring
 - Do not use empty terminals during wiring I/O to other usage.
 - Consider a countermeasure for lots of noises.
- Cleaning
 - In cleaning the unit, use dry cloth.
 - Do not use organic solvent.
 - Turn off the power to clean this unit.

The specifications, dimentions, etc are subject to change without notice.

Table of Contents

Preface	iii
User Manual Guide	iv
User Manual Symbols.....	v
Safety Precautions.....	vi
Table of Contents	ix
1. Product introduction	11
1.1 Features.....	11
1.2 Ordering information	12
1.3 Part descriptions.....	13
2. Specifications	15
2.1 Specifications.....	15
3. Dimensions	17
3.1 1-phase	17
3.2 3-phase	19
4. Connections.....	21
4.1 1-phase	21
4.2 3-phase	23
5. Installation and initial operation.....	25
5.1 Installation.....	25
5.2 Initial display.....	25
5.1 Installation.....	25
5.3.1 Parameters.....	25
5.3.2 Monitoring Mode	26
5.3.3 Operation Mode[$\square P$].....	27
5.3.4 Setting Mode 1[$5\text{E}-1$].....	28
5.3.5 Setting Mode 2[$5\text{E}-2$].....	29
6. Parameter setting and functions.....	31
6.1 Control input	31
6.2 Functions.....	33
6.2.1 Control method[$\square - \bar{n}d$].....	33
6.2.2 Soft start function [$5\text{E}-\text{E}$].....	36

Table of Contents

6.2.3	Start limit [S-L \bar{n}] and start limit time [S-L \bar{t}]	37
6.2.4	Output slope setting [S \bar{L} OP]	37
6.2.5	Output slope manual adjustment[A-G \bar{R}]	38
6.2.6	Base-up [b-U \bar{P}]	38
6.2.7	Slow up/Slow down	39
6.2.8	Output high/low limit [H-OL]/[L-OL]	39
6.2.9	Digital input (DI)	40
6.2.10	Proportional and integral constant set of feedback control	42
6.2.11	Input correction[\bar{I} n-b]	42
6.2.12	Input slope correction [S \bar{P} AN]	43
6.2.13	Display value content selection [di SP], bar graph content selection [bAR]	43
6.2.14	Load resistance display method [dr ES]	43
6.2.15	Full load auto recognition [F-Ld]	44
6.2.16	Parameter lock [Lo \bar{C} L]	44
6.3	Alarm	45
6.3.1	Overcurrent alarm [o \bar{C} -R]	45
6.3.2	Current limit[\bar{C} -L \bar{n}]	45
6.3.3	Current alarm [\bar{C} -RL]	46
6.3.4	Overvoltage alarm [o \bar{V} -R]	46
6.3.5	Fuse disconnection alarm [FUSE]	46
6.3.6	Heatsink overheating alarm [tE \bar{n} P]	46
6.3.7	Element error alarm [S \bar{C} r]	47
6.3.8	Heater disconnection alarm [Hb-R]	47
7.	Factory default	49
8.	Maintenance	51
8.1	Fuse	51
8.2	Thyristor (SCR)	52
9.	Modbus Mapping Table	53
9.1	Function code 3(0X03)=Read holding registers	53
9.2	Function code 4(0x04)=Read input registers	53
9.3	Function code 6(0x06) = write single registers	54
9.4	Function code 16(0x10) = write multiple registers	54
9.5	Address mapping table	55
9.5.1	Input registers	55
9.5.2	Holding registers	57

1. Product introduction

1.1 Features

- Accurate feedback control (static current, static voltage, static power) by RMS measurement
- Phase control and zero-crossing cycle control (fixed/variable cycle) method for various load control
- Remote monitoring and remote control
- Supports Modbus RTU protocol by RS485 communication
- Fast response speed by high-speed CPU
- Built-in customizable 6 digital inputs (DI)
- Basic variable alarm outputs; current error, heater disconnection (heater some disconnection detection), etc.
- Supports multi input of control input signal (current, voltage, potentiometer, etc)
- Enables to install control part separately
- Applicable load: all loads such as super kanthal, platinum, molybdenum, carbon, halogen lamp, chrome, nickel, etc.

1.2 Ordering information

DPU	1	2	A	—	025	R					
							Option	R	RS485 communication		
								D	Remote Display Unit		
								A	Remote Display Unit + RS485 communication		
								N	No option		
								025	25 A	200	200 A
								040	40 A	250	250 A
								050	50 A	350	350 A
								070	70 A	400	400 A
								080	80 A	500	500 A
								100	100 A	600	600 A
								120	120 A		
								150	150 A		
								180	180 A		
									1-phase	3-phase	
								A	0 to 70 A	0 to 50 A	
								B	80 to 200 A	70 to 200 A	
								C	250 to 350 A		
								D	400 to 600 A		
								E	Option		
								1	110 V		
								2	220 V		
								3	380 V		
								4	440 V		
								1	1-phase		
								3	3-phase		
								DPU	Digital Power Controller Unit		

1.3 Part descriptions

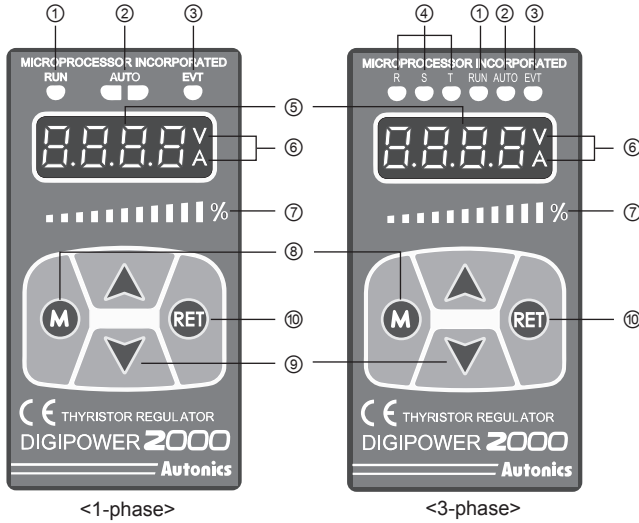

- ① RUN lamp: Turns ON in RUN, turns OFF in STOP.
- ② AUTO lamp: Turns ON in AUTO, turns OFF in MANUAL.
- ③ EVT lamp: Turns ON in Digital Input (DI-1 to 3) ON, flashes in alarm output.
- ④ R, S, T lamp: Turns ON differently by displayed value in display part.
Ex) When R, S lamps turn ON, it displays voltage between R-S line
- ⑤ Display part: Displays selected display value content in RUN mode,
Displays parameter and set value in SET mode.
- ⑥ V, A lamp: V lamp turns ON when displaying voltage,
A lamp turns ON when displaying current,
V, A lamps turn ON when displaying power,
V, A lamps turn OFF when displays resistance and input value.
- ⑦ Bar display: Turns ON as 0 to 100% ratio for selected display value.
- ⑧ **M** key: Used to enter parameter mode, monitoring mode and to move between parameters.
- ⑨ ▲, ▼ key: Used to move setting modes and to set parameters.
- ⑩ **RET** key: Used to return to RUN mode from SET mode

2. Specifications

2.1 Specifications

Series	DPU			
Number of phases	1-phase	3-phase		
Power supply	110 VAC / 220 VAC / 380 VAC / 440 VAC (FAN and control power 220 VAC 50/60 Hz separately)			
Allowable voltage	90 to 110% of rated voltage	85 to 115% of rated voltage		
Rated frequency	50/60 Hz (auto recognition), allowable frequency range: ± 2 Hz			
Min. load current	1 A			
Output range	Phase control: 5 to 98%, Z.C. control : 0 to 100%			
Control method ^{※1}	<ul style="list-style-type: none"> • Phase control: Normal control(Non-Feedback), static voltage/static current/static power control(Feedback) • Cycle control(Z.C.): Fixed cycle control, Variable cycle control • ON/OFF control(Z.C.) 			
Load	<ul style="list-style-type: none"> • Phase control: resistance load, inductive load • ON/OFF, Cycle control: resistance load 			
Power consumption	Max. 7 W (except FAN operation power)	Max. 10 W (except FAN operation power)		
Display method	<ul style="list-style-type: none"> • Display value and SV display: 7Segment 4digit • Status display: 4LED • Display value percentage display: 11LED Bar 	<ul style="list-style-type: none"> • Display value and SV display: 7Segment 4digit • Status display: 6LED • Display value percentage display: 11LED Bar 		
Output accuracy	<ul style="list-style-type: none"> • Static voltage feedback control: Within $\pm 3\%$ F.S. of rated voltage (within variable $\pm 10\%$ F.S. of rated voltage) • Static current feedback control: Within $\pm 3\%$ F.S. of rated voltage (within variable 1 to 10 times of rated resistance) • Static power feedback control: Within $\pm 3\%$ F.S. of rated voltage (within variable 1 to 10 times of rated resistance) • Normal control: within $\pm 10\%$ F.S. of rated voltage 			
Set method	By front keys, By communication			
Control input	<ul style="list-style-type: none"> • Auto: 4-20 mA / 0-20 mA / 0-5 VDC / 1-5 VDC / 0-10 VDC / voltage pulse(0/12 VDC) / no-voltage input(ON/OFF) / communication input(RS485) • Manual: inside 10 kΩ VR, outside 3 to 10 kΩ VR (min. 2 W) 			
Digital input(DI)	AUTO/MAN switching, RUN/STOP switching, RESET, Output holding, SP setting (SP1 to 6)			
Display content	Control input, load voltage, load current, load power, load resistance, power supply frequency			
Min. display output	Min. 2.5% of rated voltage/current			
Option output	RS485 communication output(Modbus RTU method), [max. 32 units]			
Dielectric strength	2000 VAC 50/60 Hz for 1 min.(between input terminal and power terminal)			
Vibration	0.75 mm amplitude at frequency of 5 to 55 Hz (for 1 min.) in each of X, Y, Z directions for 2 hours			
Insulation resistance	Min. 200 M Ω (at 500VDC megger)			
Noise resistance	Square shaped noise by noise simulator (pulse width 1 μ s) ± 2 kV			
Environment	Ambient temperature	-10 to 50 °C, storage : -20 to 80 °C		
	Ambient humidity	5 to 90%RH		
Approval	CE			
Unit weight	<ul style="list-style-type: none"> • A Size: 3.0 kg • B Size: 5.5 kg 	<ul style="list-style-type: none"> • C Size: 11.0 kg • D Size: 17.5 kg 	<ul style="list-style-type: none"> • A Size: 6.5 kg • B Size: 11.5 kg 	<ul style="list-style-type: none"> • C Size: 20.0 kg • D Size: 35.5 kg

※1. Variable cycle control is only for 1-phase model.

※Environment resistance is rated at no freezing or condensation.

Communication specifications

Application standard	Compliance with EIA RS485
Max. connections	64 channels(address : 01 to 64, auto set)
Communication type	2-wire half duplex
Synchronization method	Asynchronous
Communication distance	Max. 800m
Communication speed	38,400 bps
Communication response time	5 to 99ms
Start bit	1bit (fixed)
Data bit	8bit (fixed)
Parity bit	None(fixed)
Stop bit	2bit(fixed)
Protocol	ModBus RTU(※1 character = fixed 11bit)

3. Dimensions

3.1 1-phase

(1) A Size: DPU1□A-25 / 40 / 50 / 70

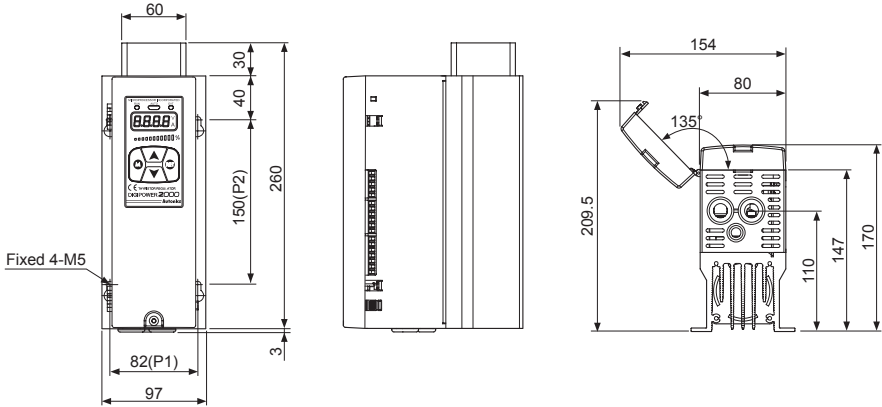

※25A, 40A, 50A are not attached a fan.

(2) B Size : DPU1□B - 80 / 100 / 120 / 150 / 180 / 200

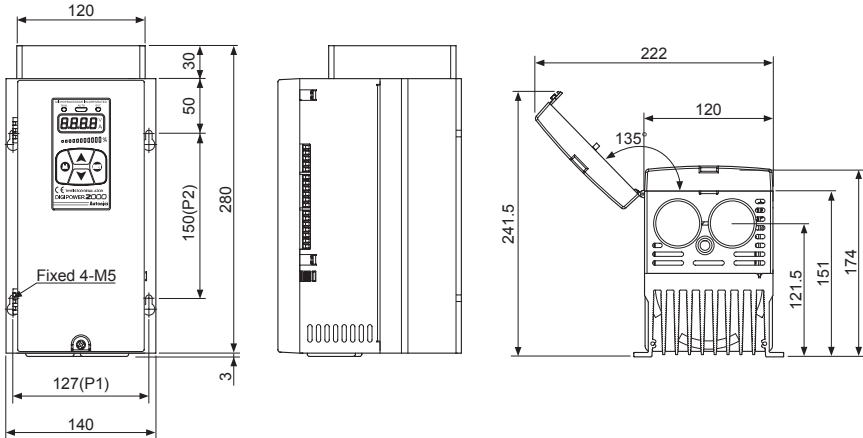

(3) C Size: DPU1□C - 250 / 350

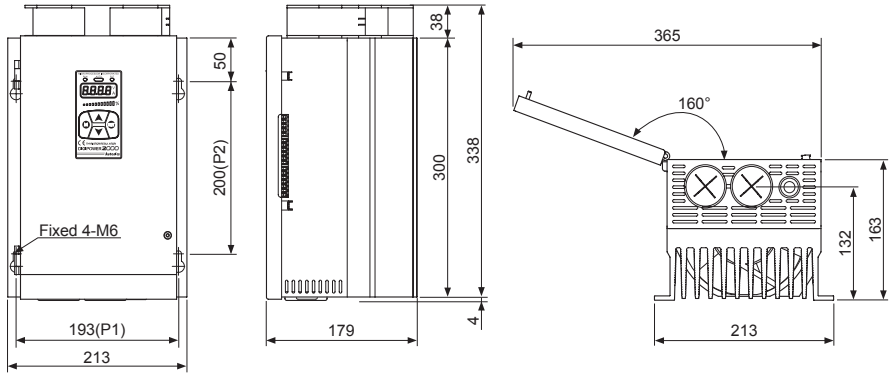

(4) D Size : DPU1□D - 400 / 500 / 600

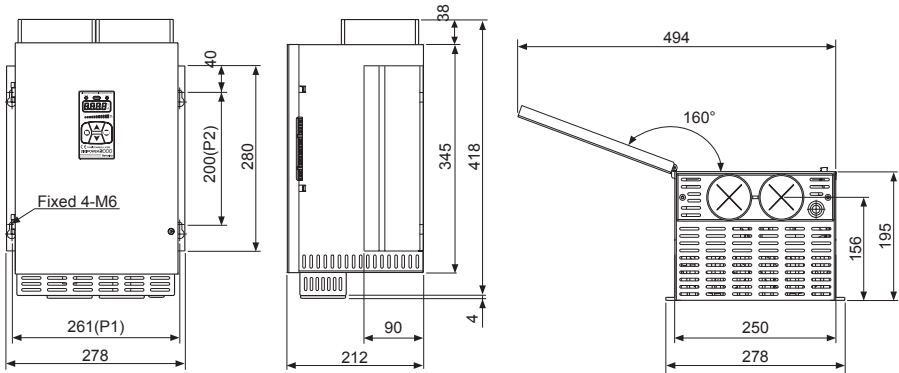

※In case of remote display unit + RS485 communication option,

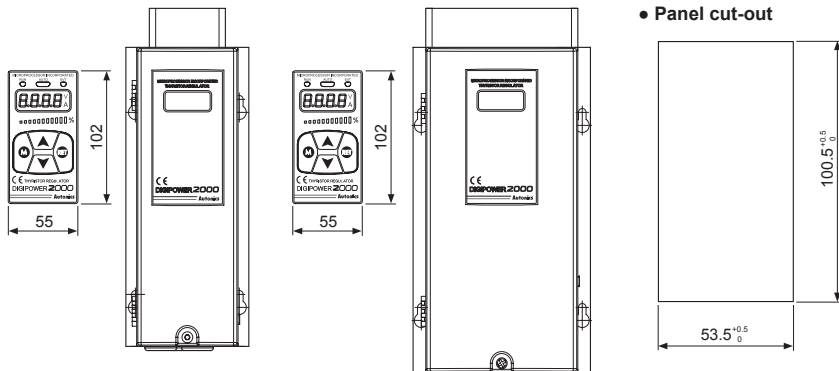

It is recommended for remote panel to use max. 5 m to prevent noise. (Check the length when ordering it.)

3.2 3-phase

(1) A Size : DPU3□A - 25 / 40 / 50

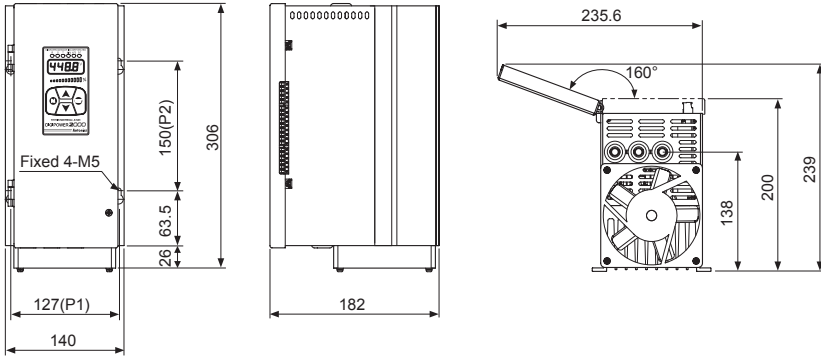

(2) B Size : DPU3□B - 70 / 80 / 100 / 120 / 150 / 180 / 200

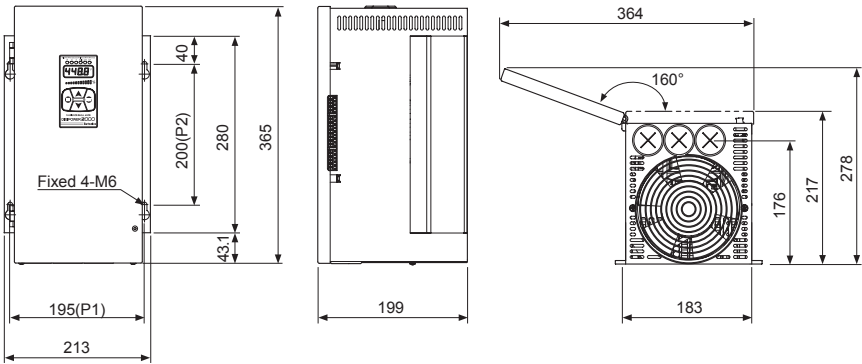

※ In case of remote display unit + RS485 communication option,

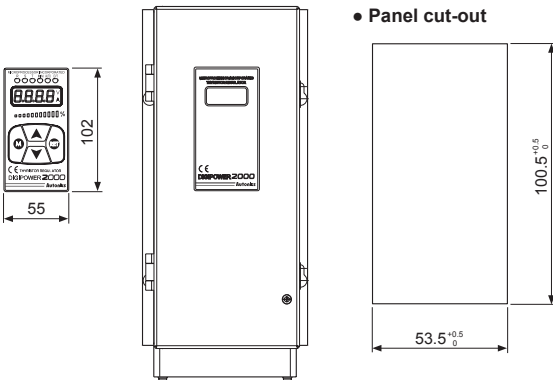

(3) C Size : DPU3□C - 250 / 350

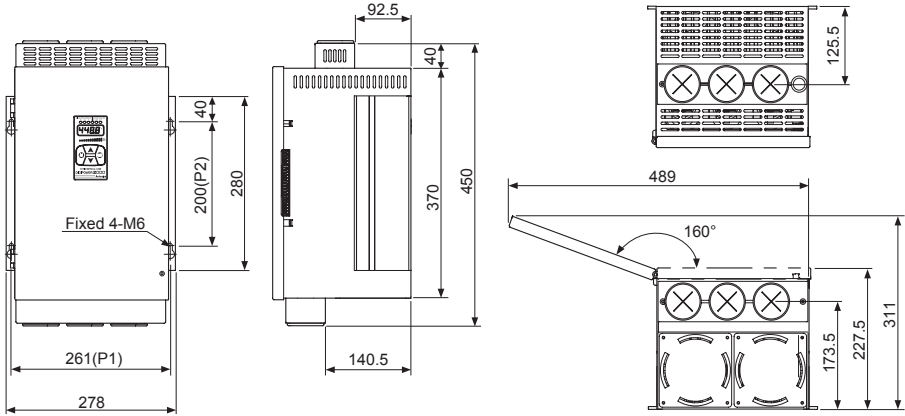

(4) D Size : DPU3□D - 400 / 500 / 600

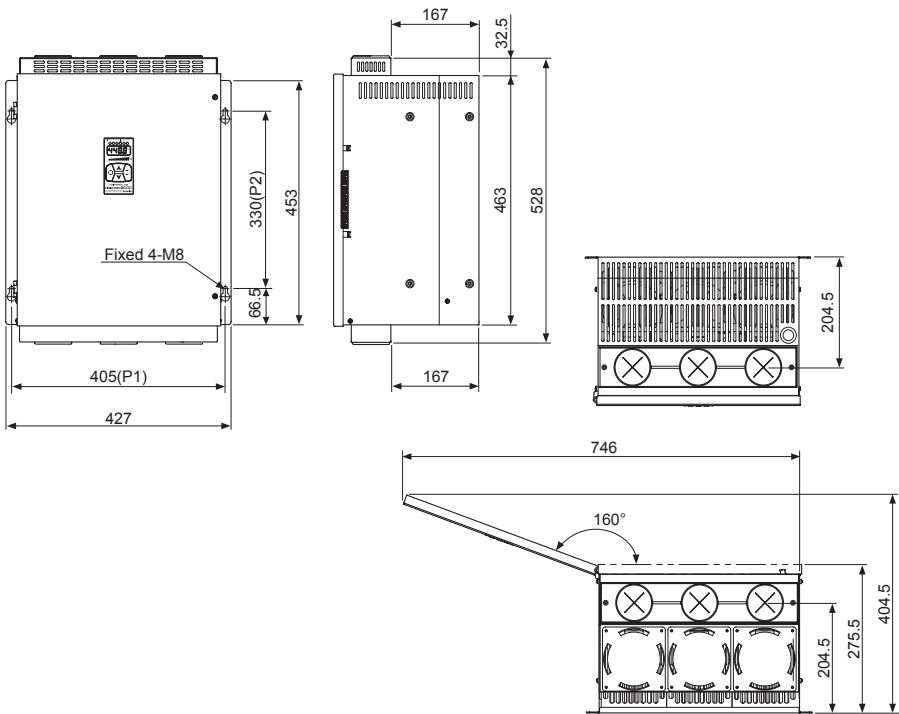

4. Connections

4.1 1-phase

• A Size

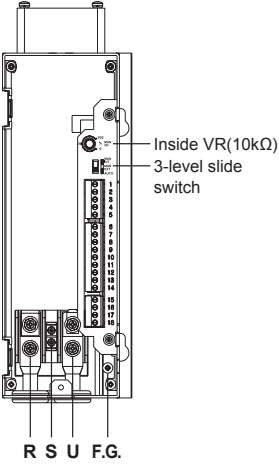

• B Size

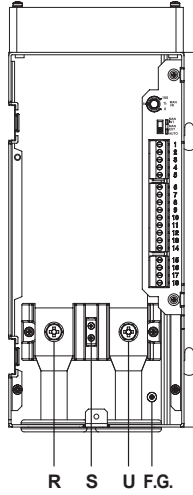

• C Size

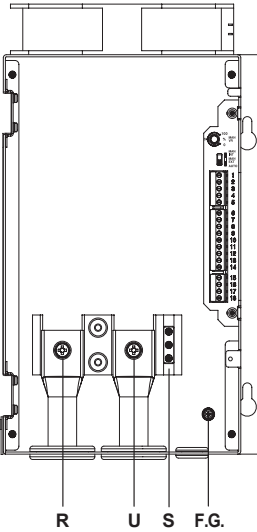

• D Size

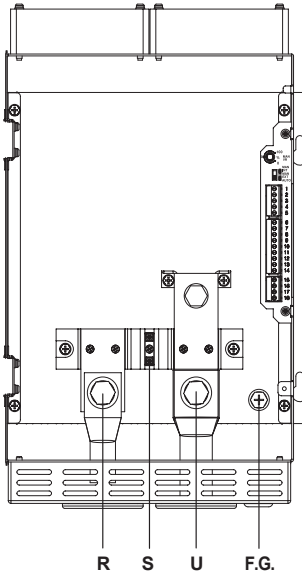

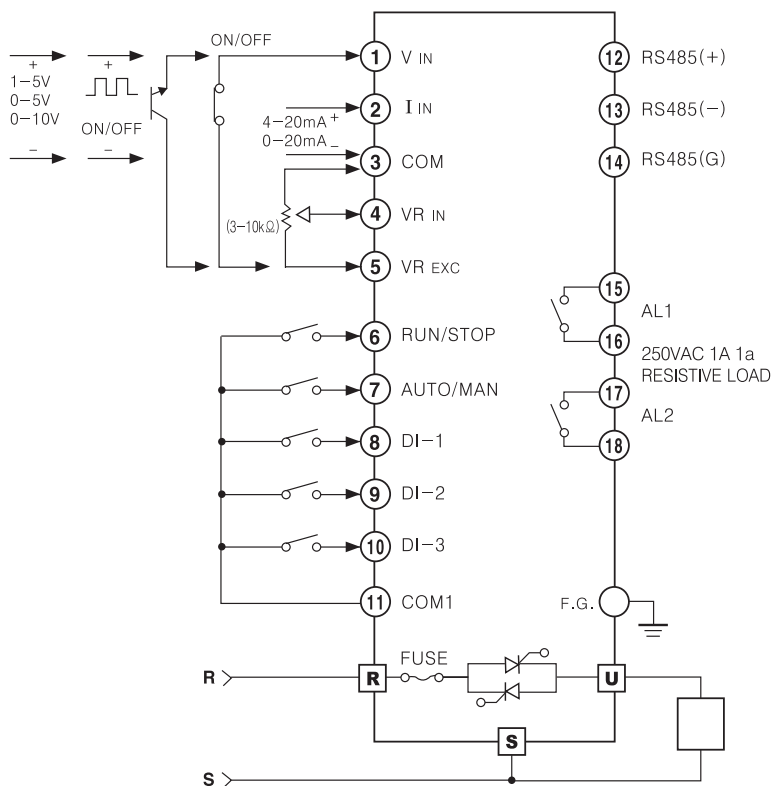

- ※1. Do not mix noise to input cable.
It is recommended to use shield cable,
twisted cable as input cable for effective noise.
- ※2. If there is possible to affect inductive noise,
it is recommended to use shielded cable at high-frequency power for effective noise.
- ※3. DI input switch should be for low current and ON resistance should be max. 20 Ω (including cable resistance).
- ※4. DI input terminals are COM, DI-1 to 3, RUN, AUTO.
- ※5. For remote display unit option model,
use connection cable as our standard cable.
- ※6. When connecting ⑥, ⑩, it operates as MANUAL. When connecting, ⑥, ⑦, ⑩,
it operates AUTO.

4.2 3-phase

(1) A Size : DPU3□A - 25 / 40 / 50

• A Size

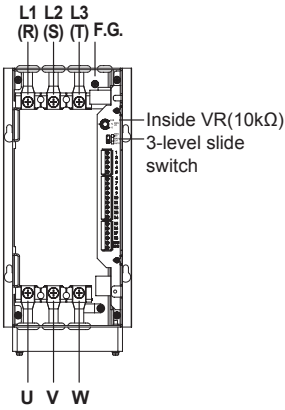

• B Size

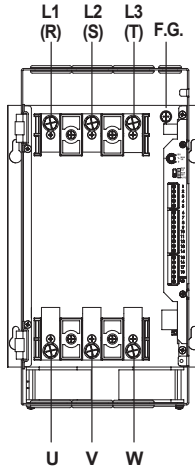

• C Size

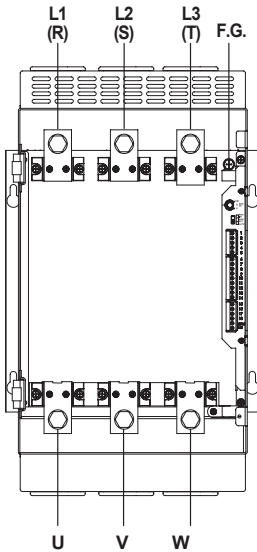

• D Size

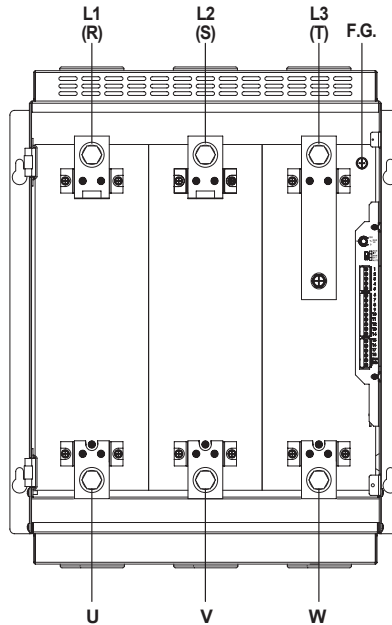

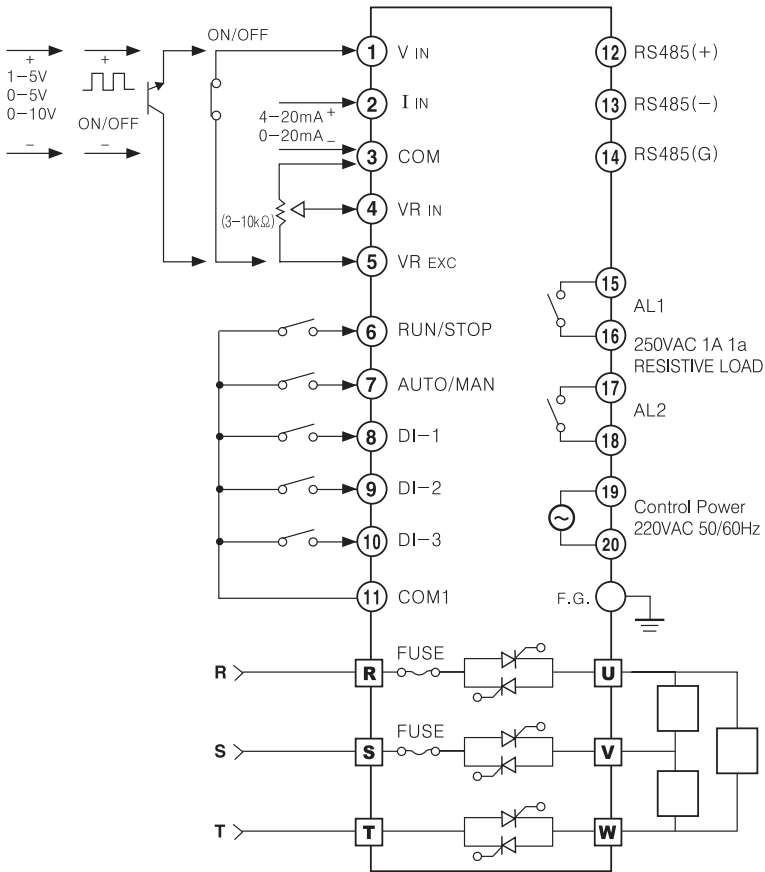

- ※1. Do not mix noise to input cable.
It is recommended to use shield cable, twisted cable as input cable for effective noise.
- ※2. If there is possible to affect inductive noise,
it is recommended to use shielded cable at high-frequency power for effective noise.
- ※3. DI input switch should be for low current and ON resistance should be max. 20Ω
(including cable resistance).
- ※4. DI input terminals are COM, DI-1 to 3, RUN, AUTO.
- ※5. For remote display unit option model,
use connection cable as our standard cable.
- ※6. When connecting ⑥, ⑩, it operates as MANUAL. When connecting, ⑥, ⑦, ⑩, it operates AUTO.

5. Installation and initial operation

5.1 Installation

Turn OFF the main power and open the front cover.

Wire it according to the connection diagrams.

5.2 Initial display

When turning ON the power to the unit, front displays flash for 1sec and it displays product version, rated voltage, rated current and operates RUN mode.

① Whole flashes	② Displays product version	③ Displays rated voltage	④ Displays rated current	⑤ RUN mode

5.1 Installation

5.3.1 Parameters

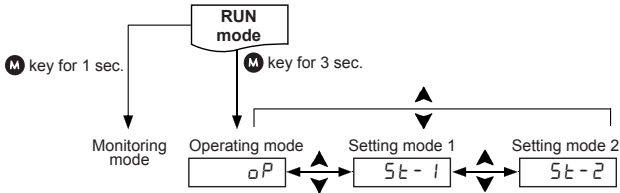

Mode	Descriptions
Monitoring Mode	Monitors input value, load voltage/current/power/resistance, power frequency.
Operating Mode[αP]	Sets parameters for DPU operation
Setting Mode 1[5t - 1]	Sets parameters for details set.
Setting Mode 2[5t - 2]	Sets parameters for alarm

5.3.2 Monitoring Mode (1) 1-phase

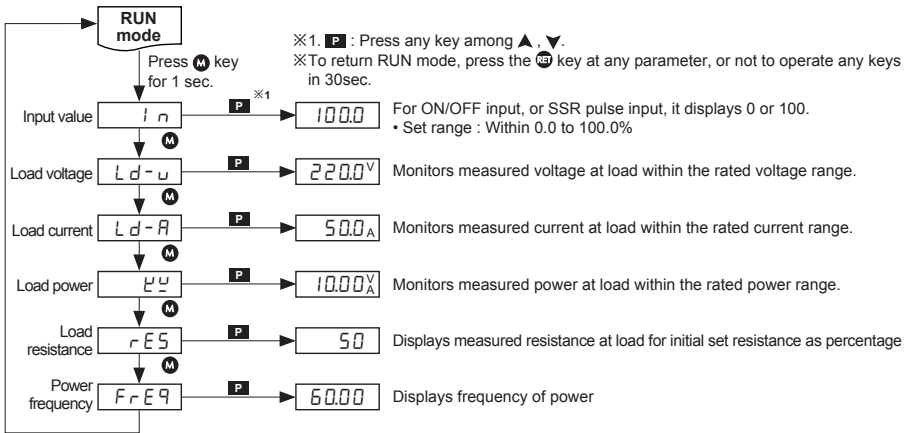

(2) 3-phase

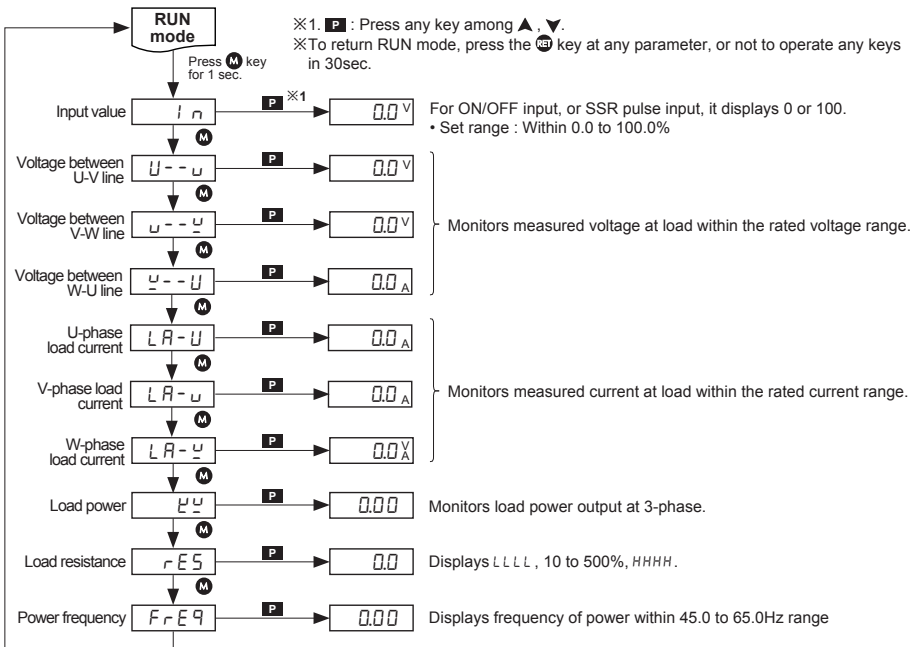

5.3.3 Operation Mode[OP]

※1. **■**: Press any key among \blacktriangle , \blacktriangledown .

※To return RUN mode, press the M key at any parameter, or not to operate any keys in 30sec.

※: : : : : This parameter may or may not appear, depending on the other parameter settings.

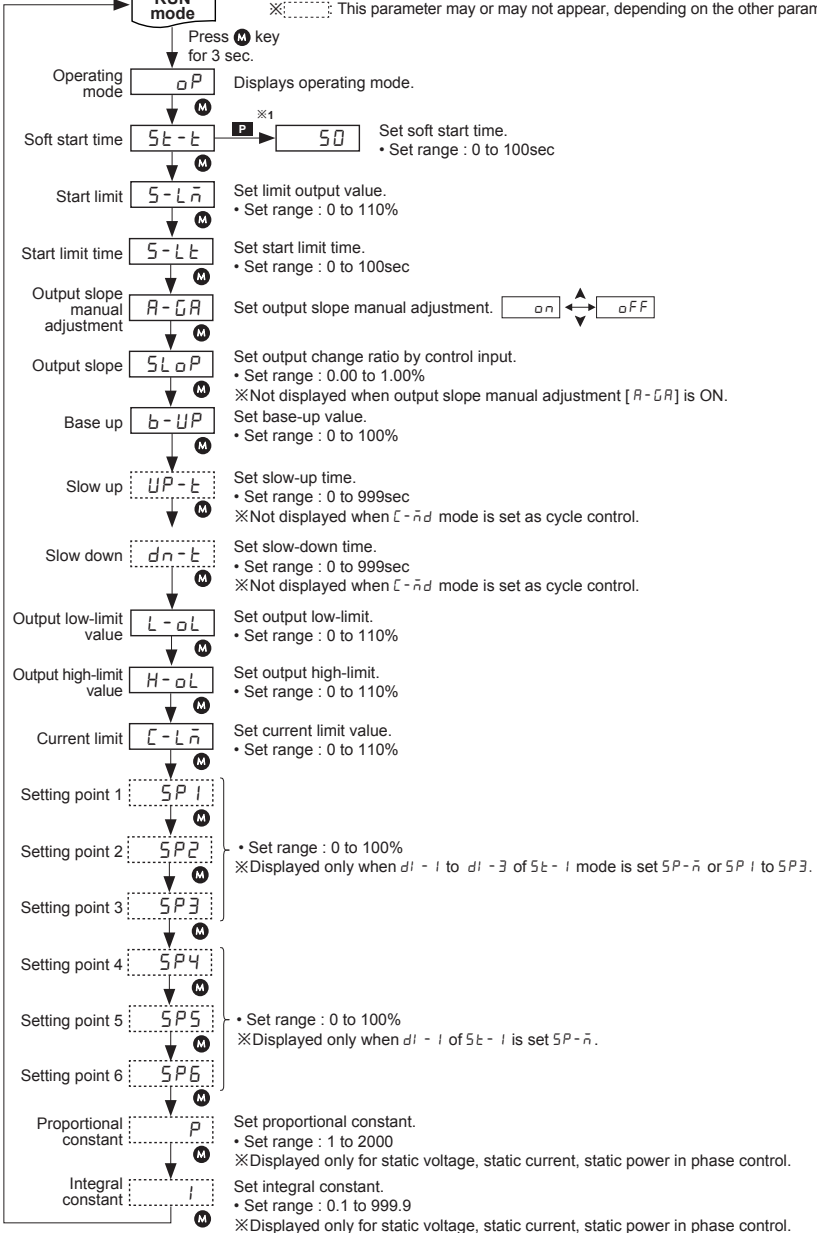

5.3.4 Setting Mode 1 [5t-1]

- ※1, P: Press any key among ▲, ▼.
 - ※If there is no operation any keys in 30sec., it returns to RUN mode.
 - ※Press the M key when entering 5t-1 setting mode in any parameters, it moves to 5t-1. Press the M key once more, it returns to RUN mode.
 - ※When setting [LoCt] as LoC2 or LoC3, and entering 5t-1, it displays only [LoCt] parameter.
 - ※:.....: This parameter may or may not appear, depending on the other parameter settings.
- Displays setting mode 1.

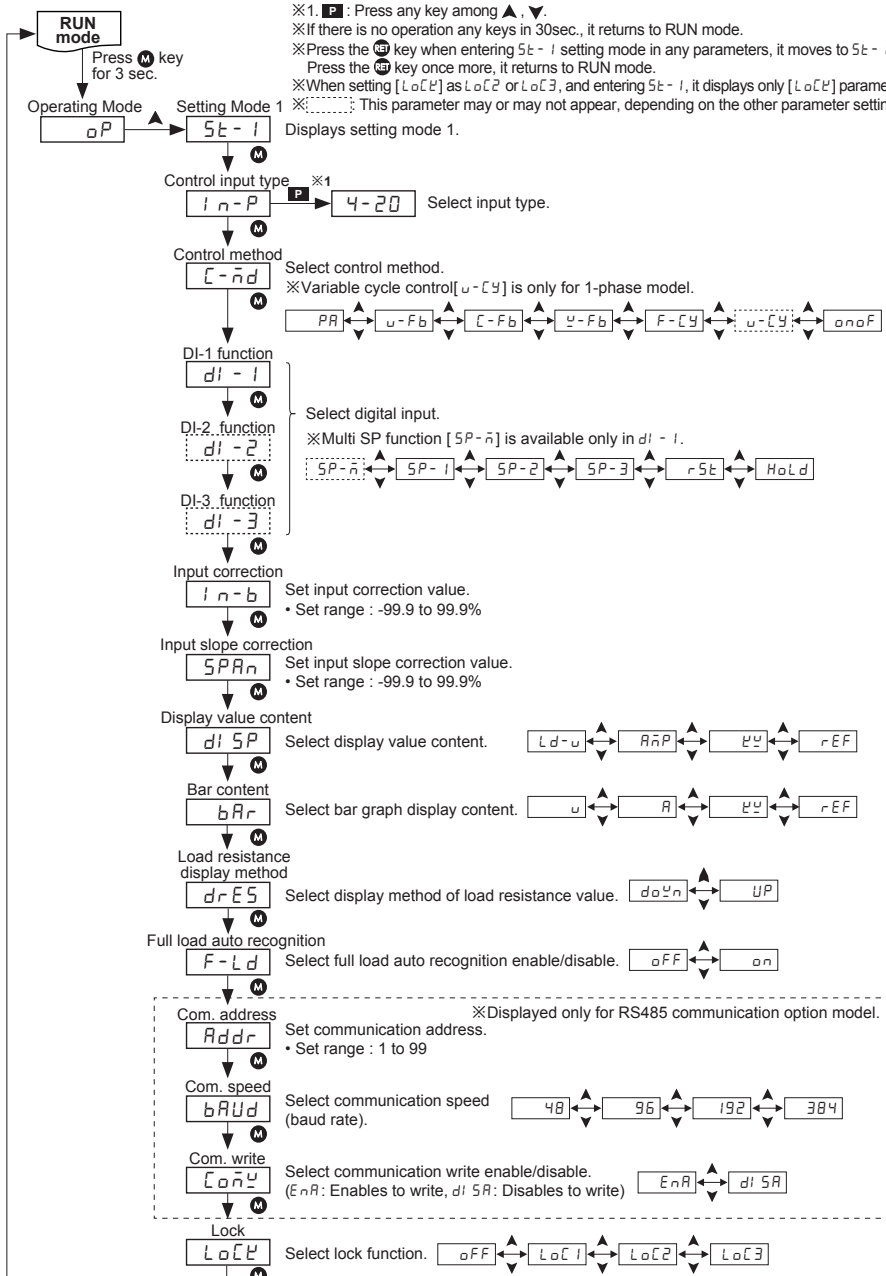

5.3.5 Setting Mode 2[5t-2]

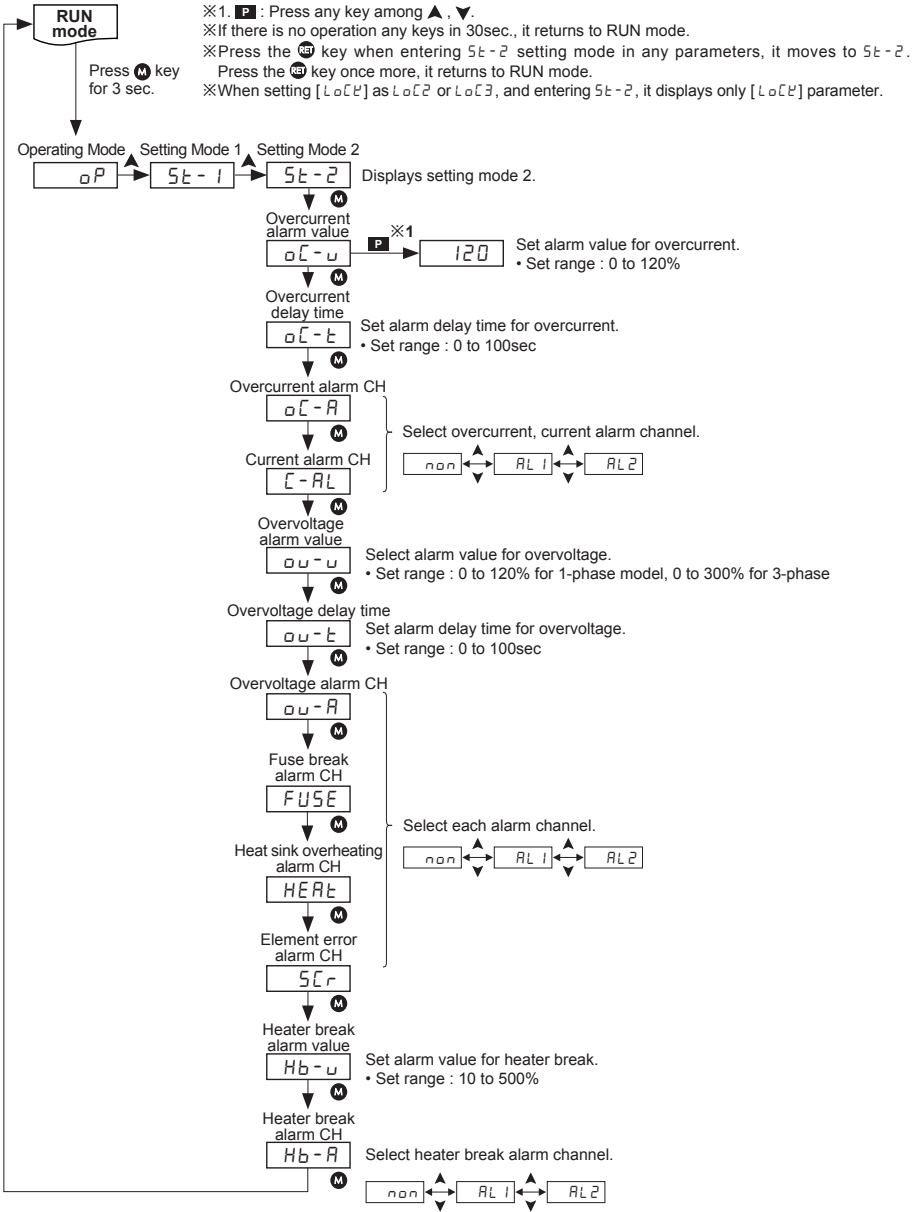

6. Parameter setting and functions

6.1 Control input

(1) Input type

Type				Parameter	
AUTO input	Analog input	Current	4-20mA	Input impedance 100Ω	4-20
			0-20mA		0-20
		Voltage	1-5VDC	Input impedance 25Ω	1-5
			0-5VDC		0-5
	0-10VDC		0-10		
	ON/OFF input	Voltage pulse	0/12VDC	—	55r
No-voltage pulse		ON/OFF			
Com. input	RS485	—	—	□□□	
MANUAL input		Inside VR	10kΩ	—	—
		Outside VR	3 to 10kΩ	—	—

(2) Input selection

In AUTO input, select it at control input type [I n - P] at setting mode1.

In MANUAL input, set output slope manual adjustment [R - CR] in operating mode as OFF and select the input by the inner 3-level slide switch.

- Output slope manual adjustment [R - CR] setting as OFF: Select the input by the inner 3-level slide switch.

Type	Description
MAN INT	Adjust output slope with the inside VR
MAN EXT	Adjust output slope with an outside VR
AUTO	No function

(3) RMS display

This unit measures and displays RMS for accuracy.

At pure resistance load, in normal control, when input is 4-20mA and rating is 220V, it displays as below.

Input	4mA	8mA	12mA	16mA	20mA
MV	0%	25%	50%	75%	100%
Display voltage	0.0V	70V	155.5V	209.7V	220.0V

In case of static voltage or static current, voltage and current displays as below.

Input	4mA	8mA	12mA	16mA	20mA
MV	0%	25%	50%	75%	100%
Display voltage (static voltage control)	0.0	55.0	110.0	165.0	220.0
Display voltage (static current control)	0.0	12.5	25.0	37.5	50.0

6.2 Functions

6.2.1 Control method [C - n d]

Control method	Control mode	Parameter
Phase control	Normal mode	PR
	Static voltage mode	U - Fb
	Static current mode	C - Fb
	Static power mode	Y - Fb
Cycle control	Fixed cycle control	F - CY
	Variable cycle control ^{※1}	U - CY
	ON/OFF control	o n o F

※1. Variable cycle control is only for 1-phase model.

(1) Normal mode [PR]

It is general output method to divide control angle proportionally according to control input signal and to output it. The below figure is for output characteristics. It may cause lack power and over-power based on the center of control input.

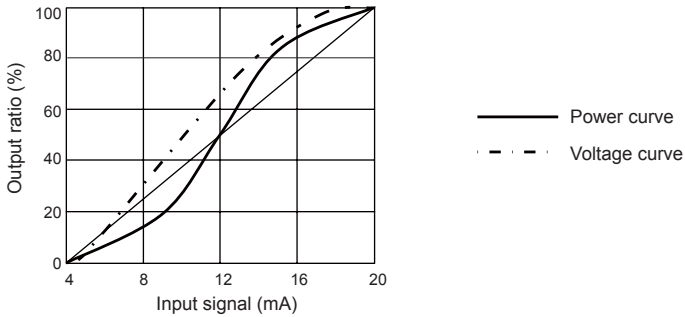

(2) Static voltage mode [U - Fb]

At low temperature coefficient load (iron, chrome, nichrome, etc) of electrical resistance, it outputs constant output which is proportion to control input not to change output voltage for power supply variation, load resistance variation.

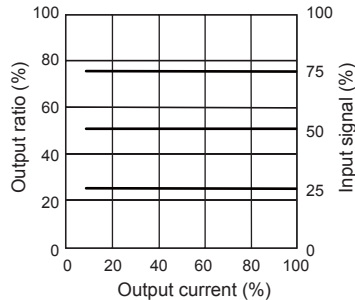
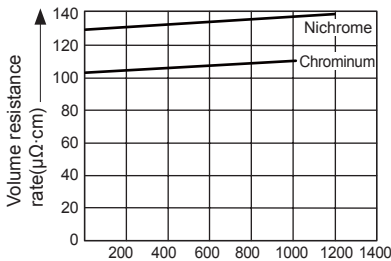

(3) Static current mode [$E - F_b$]

If temperature coefficient of load (platinum, molybdenum, tungsten, etc) changes 6 to 12 times based on room temperature, it outputs constant current which is proportion to control input not to change output voltage for power supply variation, load resistance variation.

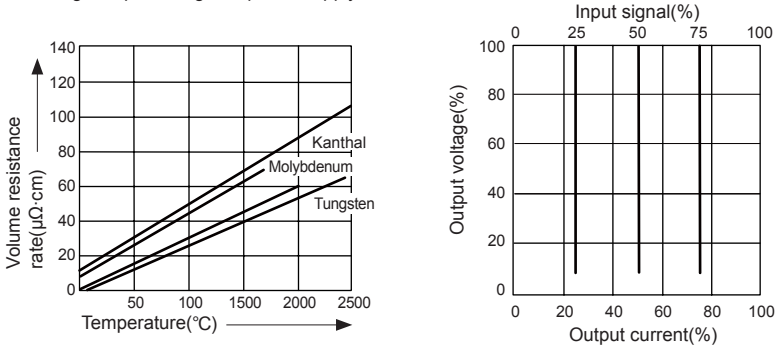
**(4) Static power mode [$Y - F_b$]**

It outputs constant power which is proportion to control input even though load variation and power supply variation. It is proper control method for a heater which resistance value variation by carbide(SiC) heating is big.

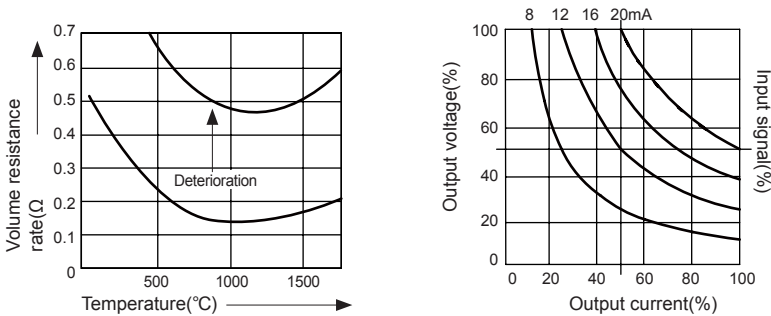

Output characteristics is proper 50% of the curve which connects the point (A) [output voltage 100% × output current 50%] and the point (B) [output voltage 50% × output current 100%].

The current output capacity of this unit should be over two times of load capacity.

(5) Fixed cycle control [F - CY]

During fixed cycle (60 cycles) of load power, it repeats ON/OFF cycle as constant ratio according to control input signal and controls the power supplies on the load.

- Fixed cycle (60 cycles) control – When controlling output as 40%

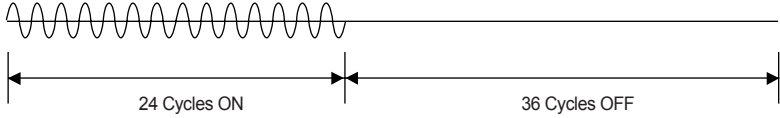

- Fixed cycle (60 cycles) control – When controlling output as 90%

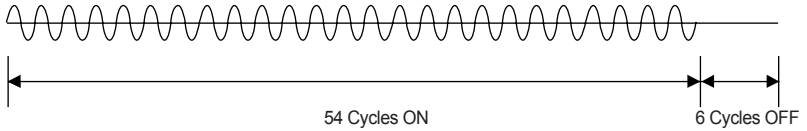

(6) Variable cycle control [V - CY]

Variable cycle control controls required power using min. cycles of AC sine wave according to control input signal and optimize temperature changes of the subject.

- Variable cycle control – When controlling output as 30%

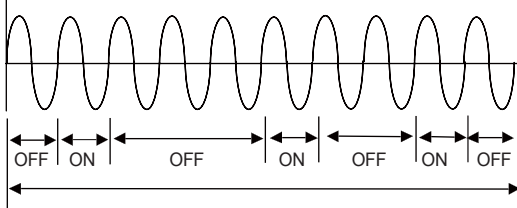

- ON/OFF control method [ONOFF]

The method when control input is OFF, output is OFF(0%), when it is ON, output is ON(100%). (same as SSR)

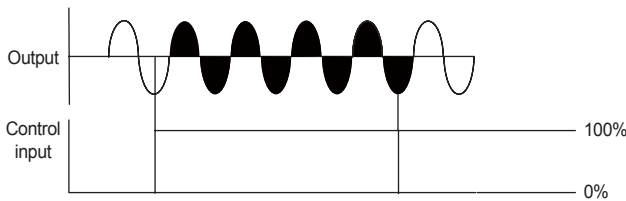

6.2.2 Soft start function [5E - E]

When controlling the load which has inrush current (platinum, molybdenum, tungsten, infrared lamp, etc) in power ON, or when control input changes rapidly, it prevents the load to increase output gradually within the set time. Set the time for soft start.

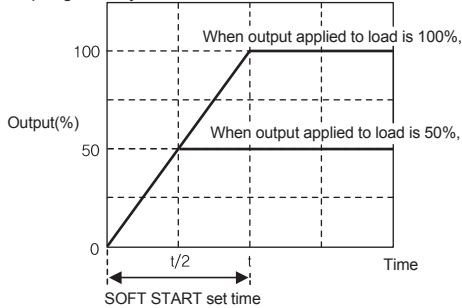

Regardless of control method setting (phase control or cycle control), it operates as phase control.

It operates when it is RUN mode from STOP status after supplying power or reset. (when it reaches to the target output value, soft start function ends.)

When the target output is 0%, (control input 0%), soft start function does not operate.

- Set range: 0 to 100 (unit: %)



Ex.

Soft start set time (t) is the time up to 100% increase of output applied to load. When the final target output value is 50%, taken time to reach is $t/2$.

Reaching time to the final target output value = target output (%) $\times t$ If soft start time is 25 sec., final target output is 80%, reaching time to the final target output value is $0.8 \times 25 = 20$.

6.2.3 Start limit [5-Ln] and start limit time [5-Lt]

When power is ON, changing to RUN status from STOP status, or alarm reset, set limit output value and time to prevent the inrush current or error current.

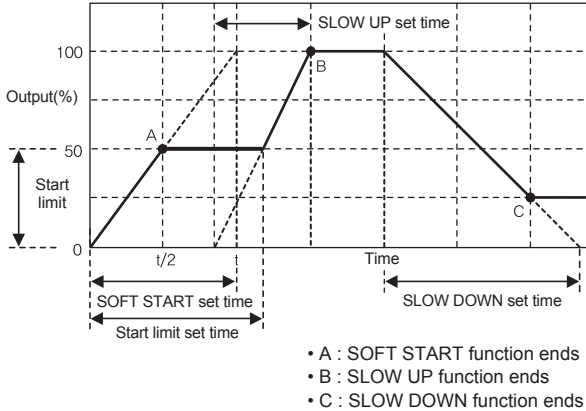

- A: Soft start [5t-t] function ends
- B: Slow up[UP-t] function ends
- C: Slow down[dn-t] function ends

Regardless of control method setting (phase control or cycle control), it operates as phase control.

- Start limit [5-Ln] set range: 0 to 110 of output (unit: %)
- Start limit time [5-Lt] set range: 0 to 100 sec.(unit: sec.)

6.2.4 Output slope setting [5LdP]

This function is to set output changed ratio by control input from 0.00 to 1.00 range.

Output value when setting slope is input(%) X slope value.

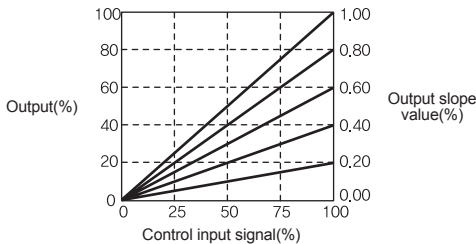

6.2.5 Output slope manual adjustment [R - CR]

This function is to adjust manually (inside or outside VR) output value ratio for control input.

When setting AUTO GAIN function as ON in AUTO operation, [L o P] is not displayed. It displays slope value by the inside or outside VR input.

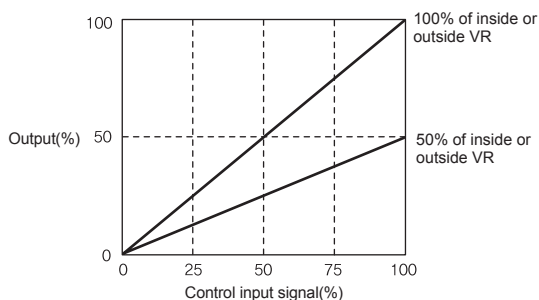

- Output slope manual adjustment [R - CR] setting as ON: Set output slope by the inner 3-level slide switch

Type	Description
MAN INT	Adjust output slope with the inside VR
MAN EXT	Adjust output slope with an outside VR
AUTO	No function

6.2.6 Base-up [b - UP]

This function is to add base-up set value to input signal.

It is available only when output low-limit value is 0%.

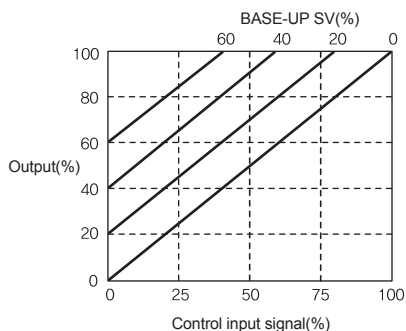

When setting base-up, output value is input (%) X slope value + base-up set value. It is limited by start limit value at initial start.

- Set range: Base-up set value (%) < Output high-limit value

6.2.7 Slow up/Slow down

It is same purpose as soft start function.

Soft start starts only one time at first but slow up/slow down function start during operation.

Regardless of control method setting (phase control or cycle control), it operates as phase control.

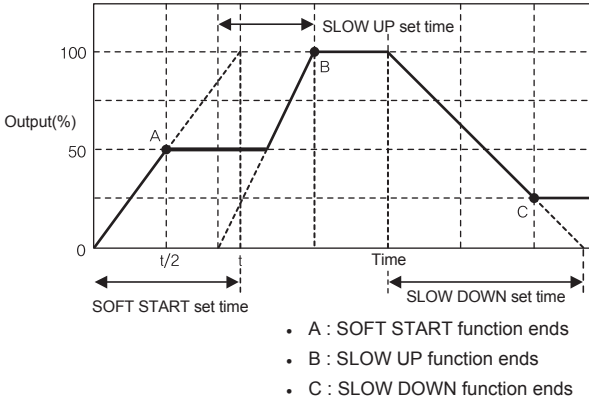

A : Soft start ends, B : Slow up ends, C : Slow down ends

When it reaches to the target output value, slow up/slow down functions end. When it sets as '0', slow up/slow down do not operate.

- Set range: 0 to 100 (unit: sec.)

6.2.8 Output high/low limit [H-σL]/[L-σL]

This function is to high/low limit output range to protect load.

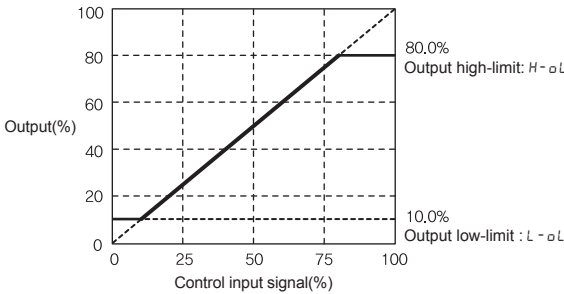

- Set range: 0 < output low limit value < output high limit value < 100 (unit: %)

6.2.9 Digital input (DI)

Below functions are available by terminal input.

Digital input has five terminals; AUTO/MANUAL terminal, RUN/STOP terminal, and DI-1 to 3 terminals. Select the function for each input terminal of DI-1 to 3.

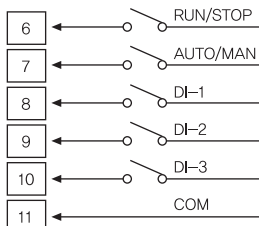

(1) AUTO/MANUAL selection [no.7 – no.11 terminals]

Select AUTO(close)/MANUAL(open) input by terminal input.

AUTO mode controls output according to control input as analog input (voltage, current) or ON/OFF input (including SSR pulse input).

MANUAL mode controls according to control input as the inside VR adjustment or an outside VR adjustment.

When selecting AUTO (close), the front AUTO lamp turns ON or selecting MANUAL(open), the front AUTO lamp turns OFF.

(2) Run/Stop switching digital input [no.6 – no.11 terminals]

Select RUN(close)/STOP(open) operation status by terminal input.

RUN mode operates as the set contents by control input. STOP mode is standby status.

When selecting RUN(close), the front RUN lamp turns ON or selecting STOP(open), the front RUN lamp turns OFF.

(3) Digital input(DI1 to DI3) settings

Select the each function for each digital input.

When setting ON(close) to DI input, the front EVT lamp turns ON or setting OFF(open), the front EVT lamp turns OFF.

• Multi SP[5P - \bar{n}]

It is available to set total 6 SPs. When selecting [5P - \bar{n}] at [$dI - 1$], [$dI - 2$] and [$dI - 3$] parameters are not displayed and 6 parameters SP1 to SP6 to set SPs are displayed in operating mode.



Ex.

	$dI - 1$	$dI - 2$	$dI - 3$	Operating mode SP value set parameter
A	○	X	X	5P - 1 (20%)
B	X	○	X	5P - 2 (40%)
C	○	○	X	5P - 3 (60%)
D	X	X	○	5P - 4 (80%)
E	○	X	○	5P - 5 (100%)
F	X	○	○	5P - 6 (0%)
G	○	○	○	—

○: Close, X: Open

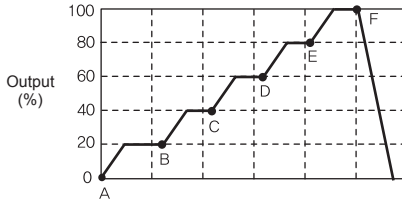

※ A, B, C, D, E, F
: Close/Open status of Digital Input

• Single SP[5P-1, 5P-2, 5P-3]

For single SP, set SP-1, SP-2, SP-3 to each digital input for output to reach to the relevant SP. It is available to set individually and duplicated and it is relevant with setting point [5P-1 to 5P-3].



Ex.

dl-1	dl-2	dl-3	Operation Mode Setting point1 to 3[5P-1 to 5P-3] parameter
5P-1	5P-2	5P-3	5P-1(ex:20%)
			5P-2(ex:40%)
			5P-3(ex:60%)

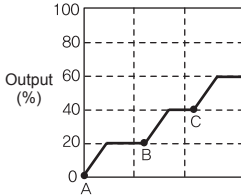

A: DI-1 is ON(CLOSE)
B: DI-2 is ON(CLOSE)
C: DI-3 is ON(CLOSE)

• RESET[r-5t]

After selecting RESET function, turn digital input ON(close) and open, this unit resets and re-starts.

• HOLD[hold]

After selecting HOLD function and digital input is ON(close), output and display value of this unit is hold. (it operates hold when digital input maintains ON(close) status.)

6.2.10 Proportional and integral constant set of feedback control

Proportional integral control: This is the combination of proportional control and integral control.

Proportional control operates soft control without overshoot and hunting for the set value.

Integral control modifies offset automatically to reach the set value stably.

The optimal values of proportional constant and integral constant are set as factory defaults.

When changing proportional constant and integral constant, it may cause response delay in feedback control or overshoot or hunting.

Proportional constant set [P], integral constant set [I] parameters are displayed when control mode is static voltage, static current, static power mode in phase control.

(1) Proportional constant set [P]

It compensates error from the target value proportionally.

If proportional constant value is small, response is fast and it may cause overshoot or hunting. If proportional constant value is big, response is slow.

- Set range: 0(0%) to 2000(100%)

(2) Integral constant set [I]

It compensates cumulative error from the target value.

The set integral constant is the time when proportional value and integral value are equal.

If integral constant value is small, response is fast and it may cause overshoot or hunting. If integral constant value is big, response is slow.

- Set range: 0.1 to 999.9 (unit: sec.)

6.2.11 Input correction[$i_n - b$]

It compensates the offset between actual input value and measured input value.

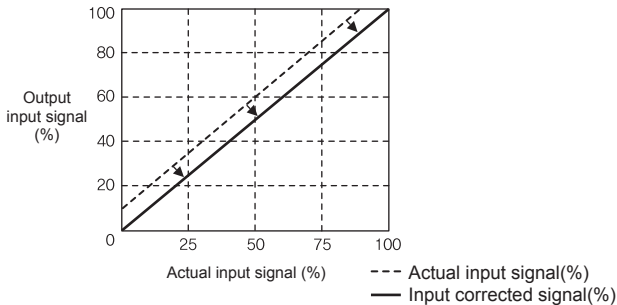

Ex.

Input type is 4 to 20mA,

When 4mA is applied and the input monitor value displays 0.5%, set IN-B as -0.5 and the input monitor value displays as 0.0.

6.2.12 Input slope correction [SPRn]

It compensates the slope of the measured 100% input for actual 100% input value.

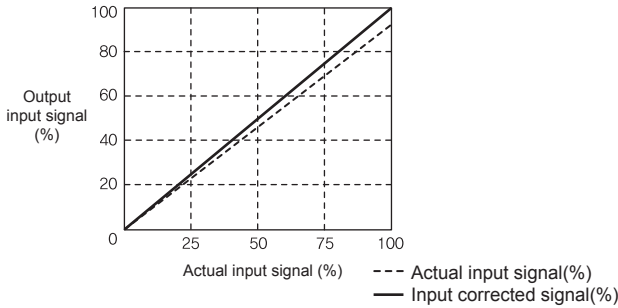

Ex. Input type is 4 to 20mA.

When 20mA is applied and the input monitor value displays 99.5%, set SPAN as 0.5 and the input monitor value is 100.0%.

- Set range: -99.9 to 99.9 (unit: %)

6.2.13 Display value content selection [dl SP],

bar graph content selection [bAr]

You can select display value content for the display part and bar graph in RUN mode.

- Display range: load voltage [L d-U], load current [L d-A], power [yP], control input [r EF]

6.2.14 Load resistance display method [dr ES]

This function is for display load resistance [r ES] into a percentage in monitoring mode when disconnecting the parallel load. You can select this value as increase rate of load resistance [UP] or as decrease rate of number of loads [doun].

- Decrease rate of number of loads [doun] displays correct decrease rate only when the connected each load resistance is same.



Ex.

R1 to R10 = 10Ω of each and load resistance (R) = 1 Ω

When disconnecting R1 to R5,

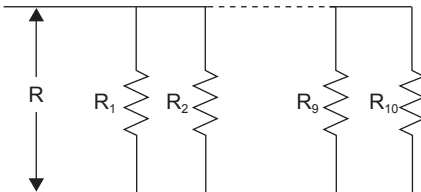

- ① Increase rate of load resistance [UP]

It is based on 100% of load resistance(R), 1 Ω . When disconnected R1 to R5, load resistance is 2 Ω and load resistance [r ES] in monitoring mode displays 200%.

- ② Decrease rate of number of loads [doun]

It is based on 100% of 10 loads (R1 to R10). When disconnected R1 to R5, the number of load are 5(R6 to R10) and load resistance [r ES] in monitoring mode displays 50%.

6.2.15 Full load auto recognition [F-Ld]

When operating load recognition function, it outputs 100% for 3 sec. Do not use this unit to the device which has problem 100% output of load.

Set F-Ld as ON in Setting Mode 1 [5t-1] group and press the **M** key, load auto recognition function operates. According to secular changes of the load, execute this function regularly.

**Note**

Be sure that when auto recognition starts, it operates 100% output for 3 sec.

**Caution**

Do not execute this function as ON without profession's consultations. When executing this function, voltage, current outputs fully. Be sure that it may cause damage to the load.

When using special load using low voltage and high current such as (super)tantalum, SiC, molybdenum, tungsten, etc, it may cause heater break alarm [H-bE].

This alarm does not have problem in operation but it occurs when it does not detect the load when using as low voltage. Set the below notes to clear the alarm.

**Note**

When using special load such as (super) tantalum, SiC, molybdenum, tungsten, [H-bE] alarm clear method:

- Set load resistance display method [dRE5] as UP in Setting Mode 1 [5t-1].
- Set heater break alarm value [Hb-u] as 500 in Setting Mode 2 [5t-2].

6.2.16 Parameter lock [L o L]

This function is to limit parameter set value check and change.

	OFF	LOC1	LOC2	LOC3
Operating Mode set group	●	●	●	◐
Setting Mode 2 set group	●	●	◐	◐
Setting Mode 1 set group	●	◐	X	X

●: Enable to check and set, ◐: Enable to check/Disable to set, X: Disable to check

6.3 Alarm

Alarm	Display	Operation in alarm	Alarm clear
Overcurrent alarm	$\alpha - \zeta$	Stops output (SCR OFF)	Re-supply the power. RESET key, Switch to STOP mode
Overvoltage alarm	$\alpha - \upsilon$		
Fuse break alarm	$FUSE^{\times 1}$		
Heatsink overheat alarm	$tE\bar{n}P$		
Element error alarm	$S\zeta^{\times 1}$		
Current alarm	ζRL	Continues operation	Automatically cleared within the set range
Heater break alarm	HbE		

※1: When it cannot return by re-supplying power because fuse is disconnected or element is error, refer to '7 Factory default'.

6.3.1 Overcurrent alarm [$\alpha \zeta - R$]

When overcurrent alarm occurs, output stops and alarm maintains. [$\alpha - \zeta$] flashes for 0.5 sec in the display part and the EVT lamp flashes for 0.5 sec.

When setting as [$n\alpha n$], alarm output does not occur but [$\alpha - \zeta$] flashes.

Alarm clears when re-supplying power, reset, or stop the unit.

(1) Overcurrent alarm value setting [$\alpha \zeta - U$]

Set overcurrent alarm value within 0.0 to 120.0% of rated current range.

(2) Overcurrent alarm delay time [$\alpha \zeta - t$]

Set overcurrent alarm delay time within 0 to 100 sec. range. After the set time, over current alarm occurs.

6.3.2 Current limit [$\zeta - L \bar{n}$]

This function limits current when using big inrush load to protect thyristor.

Especially for voltage feedback, current for load resistance value flows and it may over the rated thyristor only voltage control. Therefore, it limits current to prevent over the rated current.

- Set range: 0 to 110% (unit: %)

6.3.3 Current alarm [$C - RL$]

When it reaches to current limit value, alarm occurs.

When current occurs, control operation maintains. [$C - RL$] and display value flashes for 2 sec. in turn in the display part and the EVT lamp flashes for 0.5 sec.

When the current is under the current limit value, alarm clears.

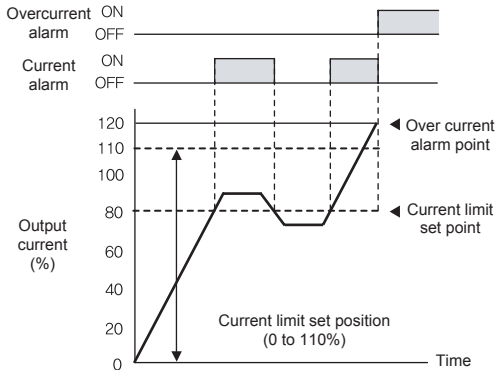

6.3.4 Overvoltage alarm [$OV - A$]

When overvoltage alarm occurs, output stops and alarm maintains.

[$OV - A$] flashes for 0.5 sec. in the display part and the EVT lamp flashes for 0.5 sec.

Alarm clears when re-supplying power, reset, or stop the unit.

(1) Overvoltage alarm value setting [$OV - U$]

Set overvoltage alarm value within 0.0 to 120.0% of rated voltage.

(2) Overvoltage alarm delay time [$OV - t$]

Set overvoltage alarm delay time within 0 to 100 sec. range. After the set time, overvoltage alarm occurs.

6.3.5 Fuse disconnection alarm [$FUSE$]

When fuse disconnection alarm occurs, output stops and alarm maintains. [$FUSE$] flashes for 0.5 sec. in the display part and the EVT lamp flashes for 0.5 sec.

Alarm clears when re-supplying power, reset, or stop the unit.

6.3.6 Heatsink overheating alarm [$TEMP$]

When the temperature of a heat sink is over 75°C, heat sink overheating alarm occurs. [$TEMP$] flashes for 0.5 sec. in the display part and AL1 or AL2 lamp turn ON. When heatsink overheating alarm occurs, output stops and alarm maintains. Alarm clears when re-supplying power, reset, or stop the unit after cooling a heatsink.

6.3.7 Element error alarm [$5\text{E}r$]

Even though output is 0% and 10% of rated current or over current flows for over 3 sec. (or over 5 cycle) continuously, element error alarm occurs.

When element error alarm occurs, output stops and alarm maintains. [$5\text{E}r$] flashes for 0.5 sec. in the display part and the EVT lamp flashes for 0.5 sec.

Alarm clears when re-supplying power, reset, or stop the unit.

6.3.8 Heater disconnection alarm [$Hb-R$]

When load resistance display method is set as [LP], it is over the set value, this alarm occurs.

[HbR] and display value flashes for 2 sec. in turn in the display part and EVT lamp flashes for 0.5 sec.

Even though heater disconnection alarm occurs, control operation continues.

It is cleared automatically when the value is below the SV of heater disconnection alarm value.

(1) Heater disconnection alarm value setting [$Hb-u$]

Regardless of control method (phase control, cycle control), it operates. For the accurate operation, over 10% of control output (phase control, cycle control) and over 30% of rated current are required.

- Set range: 10 to 500 (unit: %)

Hysteresis of heater disconnection alarm is fixed as 1% for ON/OFF interval.



Ex.

When SV for heater disconnection alarm is 50%, alarm turns ON at 50%, alarm turns OFF at 49%.

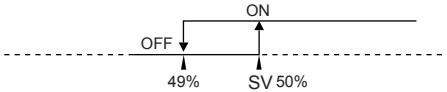

(2) Heater disconnection alarm delay time [$Hb-t$]

When load resistance display method is set as [$doun$] and load resistance value is under the SV of [$Hb-u$], alarm disconnection alarm occurs after the set delay time.

- Set range: 10, 20, 30 (unit: sec.)

7. Factory default

(1) Operation mode

Parameter	Default	Parameter	Default
S _t -t	0000	b-UP	0000
S-L _n	110.0	UP-t	0003
S-L _t	0000	dn-t	0003
A-GR	oFF	L-oL	0000
SLoP	1000	H-oL	110.0
C-L _n	110.0	SP5	0000
SP1	0000	SP6	0000
SP2	0000	P	0150
SP3	0000	I	0200
SP4	0000		

(2) Setting mode 1

Parameter	Default	Parameter	Default
I _n -P	4-20	drES	doLn
C-n _d	PR	bAr	u(1-phase)
dI-1	SP-n		U-u(3-phase)
dI-2	SP-1	F-L _d	oFF
I _n -b	0000	Rd _d r	0001
SPR _n	0000	bAU _d	384
dI SP	L _d -u(1-phase)	C _o n _u	EnR
	U-u(3-phase)	L _o C _t	oFF

(3) Setting mode 2

Parameter	Default	Parameter	Default
oC-u	110.0	ou-R	RL1
oC-t	0005	FUSE	RL1
oC-R	RL1	HEAt	RL1
C-RL	RL2	SC _r	RL1
ou-u	110.0	Hb-u	0100
ou-t	0005	Hb-R	RL2

8. Maintenance

8.1 Fuse

To prevent accident, replace a fuse every two years.

Turn OFF the power and remove the power to remove the fuse which is in the product.

Fuse position by each model

(1) 1-phase

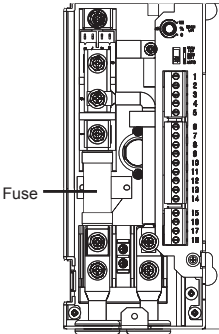

A type

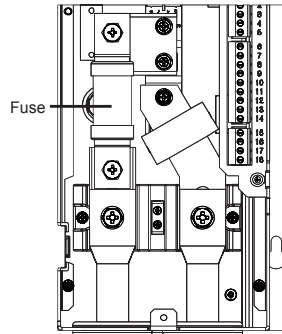

B type

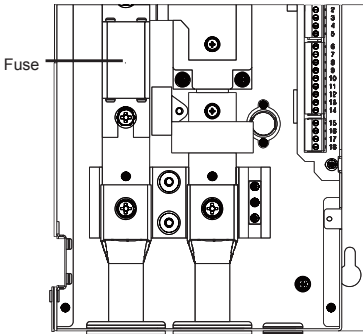

C type

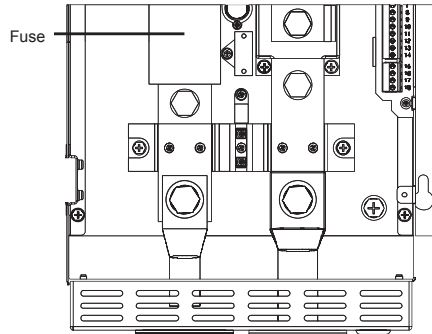

D type

(2) 3-phase

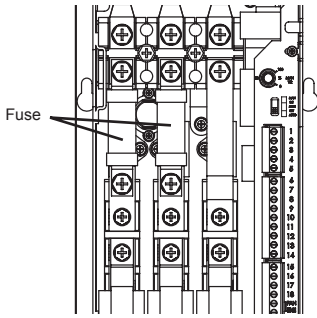

A type

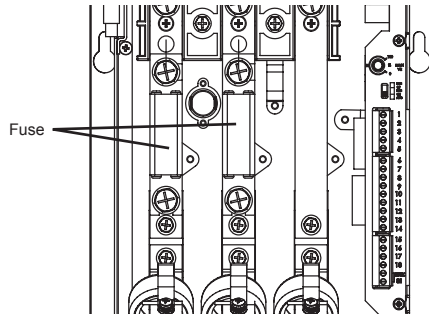

B type

**Warning**

- Use the specified fuse of Autonics.
- After replacing the fuse, check the installation of the replaced fuse properly.

8.2 Thyristor (SCR)

The 1-phase mode has one SCR element of output part and the 3-phase mode has three of that. It is normal status when the resistance between K and G is 10 to 100 Ω during checking SCR elements.

Refer to the below circuit diagram for accurate maintenance.

Assemble this unit as below circuit diagram. (Load lamp turns OFF)

When shorting TEST 1 at gate momentarily, open it to turn ON the load lamp.

When load lamp does not turn ON, SCR elements are bad conditions.

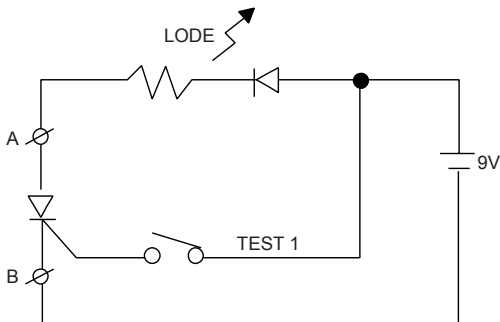

9. Modbus Mapping Table

9.1 Function code 3(0X03)=Read holding registers

(1) Request

Master to Slave							
0×01	0×03	0×00	0×00	0×00	0×16	xx	xx
Add.	Com- mand	Start address		Number of data		CRC 16	
		High	Low	High	Low	High	Low

(2) Response

Slave to Master									
0×01	0×03	0×10	0×03	0×E8	...	0×03	0×E8	xx	xx
Add.	Response command	Number of data	1st data		...	16th data		CRC 16	
			High	Low	...	High	Low	High	Low

(3) Error

Slave to Master				
0×01	0×83	xx	xx	xx
Address	Response command	Exception code	CRC 16	

※Exception code

0×01 : Not supported command code.

0×02 : Starting address of required data and transmittable address are different.

0×03 : The number of required data is over than the number of transmittable data.

0×04 : Transmittable data does not process properly.

9.2 Function code 4(0×04)=Read input registers

(1) Request

Master to Slave							
0×01	0×04	0×00	0×00	0×00	0×10	xx	xx
Address	Com- mand	Start address		Number of data		CRC 16	
		High	Low	High	Low	High	Low

(2) Response

Slave to Master									
0×01	0×04	0×10	0×03	0×E8	...	0×03	0×E8	xx	xx
Address	Response command	Number of data	1st data		...	16th data		CRC 16	
			High	Low	...	High	Low	High	Low

(3) Error

Slave to Master				
0×01	0×84	xx	xx	xx
Address	Response command	Exception code	CRC 16	

※Exception code

0×01 : Not supported command code.

0×02 : Starting address of required data and transmittable address are different.

0×03 : The number of required data is over than the number of transmittable data.

0×04 : Transmittable data does not process properly.

9.3 Function code 6(0×06) = write single registers

(1) Request

Master to Slave							
0×01	0×06	0×00	0×00	0×03	0×E8	xx	xx
Address	Command	Station		Data		CRC 16	
		High	Low	High	Low	High	Low

(2) Response

Slave to Master							
0×01	0×06	0×00	0×00	0×03	0×E8	xx	xx
Address	Command	Station		Data		CRC 16	
		High	Low	High	Low	High	Low

(3) Error

Slave to Master				
0×01	0×86	xx	xx	xx
Address	Response command	Exception code	CRC 16	

※Exception code

0×01 : Not supported command code.

0×02 : Starting address of required data and transmittable address are different.

0×03 : The number of required data is over than the number of transmittable data.

0×04 : Transmittable data does not process properly.

9.4 Function code 16(0×10) = write multiple registers

(1) Request

Master to Slave							
0×01	0×10	0×00	0×00	0×00	0×10	0×20	xx xx
Address	Command	Start address		Number of data		Number of byte	CRC 16
		High	Low	High	Low		

(2) Response

Slave to Master							
0×01	0×10	0×00	0×00	0×03	0×E8	xx	xx
Address	Command	Station		Data		CRC 16	
		High	Low	High	Low	High	Low

(3) Error

Slave to Master				
0×01	0×90	xx	xx	xx
Address	Response Command	Exception code	CRC 16	

※Exception code

0×01 : Not supported command code.

0×02 : Starting address of required data and transmittable address are different.

0×03 : The number of required data is over than the number of transmittable data.

0×04 : Transmittable data does not process properly.

9.5 Address mapping table

9.5.1 Input registers

(1) 1-phase

Address	Item	Factor
300001(0000)	Output voltage	*0.1
300002(0001)	Load current	*0.1
300003(0002)	Power	*0.1
300004(0003)	Load resistance	*0.1
300005(0004)	Power frequency	*0.01
300101(0064)	Product number H	00
300102(0065)	Product number L	00
300103(0066)	Hardware version	10
300104(0067)	Software version	10
300105(0068)	Model name 1	"DP"
300106(0069)	Model name 2	"2-"
300107(006A)	Model name 3	"00"
300108(006B)	Model name 4	" "
300109(006C)	Model name 5	" "
300110(006D)	Model name 6	" "
300111(006E)	Model name 7	" "
300112(006F)	Model name 8	" "
300113(0070)	Model name 9	" "
300114(0071)	Model name 10	" "
300115(0072)	Reserved	Reserved
300116(0073)	Reserved	Reserved
300117(0074)	Reserved	Reserved
300118(0075)	Coil start address	0
300119(0076)	Coil quantity	0
300120(0077)	Input start address	0
300121(0078)	Input quantity	0
300122(0079)	Holding reg start address	0
300123(007A)	Holding reg quantity	32
300124(007B)	Input reg start address	0
300125(007C)	Input reg quantity	5

(2) 3-phase

Address	Item	Factor
300001(0000)	Load voltage between U-V line display (Vrms)	*0.1
300002(0001)	Load voltage between V-W line display (Vrms)	*0.1
300003(0002)	Load voltage between W-U line display (Vrms)	*0.1
300004(0003)	Load current of U-phase display (Arms)	*0.1
300005(0004)	Load current of V-phase display (Arms)	*0.1
300006(0005)	Load current of W-phase display (Arms)	*0.1
300007(0006)	Current display (kw)	*0.01
300008(0007)	Load resistance display (%display for initial load)	*0.1
300009(0008)	Power frequency display	*0.01
300101(0064)	Product number H	00
300102(0065)	Product number L	00
300103(0066)	Hardware version	10
300104(0067)	Software version	10
300105(0068)	Model name 1	"DP"
300106(0069)	Model name 2	"2-"
300107(006A)	Model name 3	"00"
300108(006B)	Model name 4	" "
300109(006C)	Model name 5	" "
300110(006D)	Model name 6	" "
300111(006E)	Model name 7	" "
300112(006F)	Model name 8	" "
300113(0070)	Model name 9	" "
300114(0071)	Model name	" "
300115(0072)	Reserved	Reserved
300116(0073)	Reserved	Reserved
300117(0074)	Reserved	Reserved
300118(0075)	Coil start address	0
300119(0076)	Coil quantity	0
300120(0077)	Input start address	0
300121(0078)	Input quantity	0
300122(0079)	Holding reg start address	0
300123(007A)	Holding reg quantity	32
300124(007B)	Input reg start address	0
300125(007C)	Input reg quantity	5

9.5.2 Holding registers

(1) 1-phase

Address	Item	Factor
400001(0000)	Reference value	*0.1(1 to 1000)
400002(0001)	Start time	0 to 99
400003(0002)	Start limit	*0.1(1 to 1000)
400004(0003)	Soft start time	0 to 99
400005(0004)	Output high-limit	*0.1(1 to 1000)
400006(0005)	Output low-limit	*0.1(1 to 1000)
400007(0006)	Remote SP1	*0.1(1 to 1000)
400008(0007)	Remote SP2	*0.1(1 to 1000)
400009(0008)	Remote SP3	*0.1(1 to 1000)
400010(0009)	Remote SP4	*0.1(1 to 1000)
400011(000A)	Remote SP5	*0.1(1 to 1000)
400012(000B)	Remote SP6	*0.1(1 to 1000)
400013(000C)	Slow up time	0 to 99
400014(000D)	Slow Stop time	0 to 99
400015(000E)	Current limit	*0.1(1 to 2000)
400016(000F)	Over current value	*0.1(1 to 1100)
400017(0010)	Over current time	0 to 99
400018(0011)	Over voltage value	*0.1(1 to 1100)
400019(0012)	Over voltage time	0 to 99
400020(0013)	Load detector alarm value	*0.1(1 to 2000)
400021(0014)	Display selected contents	0 to 3
400022(0015)	Bar graph's content	0 to 3
400023(0016)	Control integer KP value	1 to 9999
400024(0017)	Control integer KI value	*0.1(1 to 999.9)
400025(0018)	Control method	0 to 6
400026(0019)	Digital input 1	0 to 4
400027(001A)	Digital input 2	0 to 4
400028(001B)	Digital input 3	0 to 4
400029(001C)	Auto ref input selector	0 to 3
400030(001D)	Load resistance display method	0 to 1

400031(001E)	Operation	Bit0... Fault Bit1... I-OC Bit2... Over current Bit3... Over volt Bit4... Over temperature Bit5... Fuse cut Bit6... Phase loss Bit7... Load open Bit8... Over SCR Bit9... Over Frequency Bit10... Run/Stop Bit11... Auto/Manual Bit12... EMS Power Bit13... Not Load
400032(001F)	Output slope (%)	*0.001(0 to 1.000)
400033(0020)	Output (%) for input 0%	*0.01(0 to 1000)
400034(0021)	Input correction	*0.1(-999 to 999)
400035(0022)	Input slope correction	*0.1(-999 to 999)
400036(0023)	Overcurrent alarm output	0 to 2 (*1)
400037(0024)	Current alarm output	0 to 2
400038(0025)	Overvoltage alarm output	
400039(0026)	Burn out fuse alarm	
400041(0028)	Heat sink temperature abnormal condition alarm	
400042(0029)	Element error alarm	
400044(002B)	Heater break alarm	

(2) 3-phase

Address	Item	Factor
400001(0000)	Reference value	*0.1(1 to 1000)
400002(0001)	Start time	0 to 99
400003(0002)	Start limit	*0.1(1 to 1000)
400004(0003)	Soft start time	0 to 99
400005(0004)	Output high-limit	*0.1(1 to 1000)
400006(0005)	Output low-limit	*0.1(1 to 1000)
400007(0006)	Remote SP1	*0.1(1 to 1000)
400008(0007)	Remote SP2	*0.1(1 to 1000)
400009(0008)	Remote SP3	*0.1(1 to 1000)
400010(0009)	Remote SP4	*0.1(1 to 1000)
400011(000A)	Remote SP5	*0.1(1 to 1000)
400012(000B)	Remote SP6	*0.1(1 to 1000)
400013(000C)	Slow up time	0 to 99
400014(000D)	Slow Stop time	0 to 99
400015(000E)	Current limit	*0.1(1 to 2000)
400016(000F)	Over current value	*0.1(1 to 1100)
400017(0010)	Over current time	0 to 99
400018(0011)	Over voltage value	*0.1(1 to 1100)
400019(0012)	Over voltage time	0 to 99
400020(0013)	Load detector alarm value	*0.1(1 to 2000)
400021(0014)	Display selected contents	0 to 3
400022(0015)	Bar graph's content	0 to 3
400023(0016)	Control integer KP value	1 to 9999
400024(0017)	Control integer KI value	*0.1(1 to 999.9)
400025(0018)	Control method	0 to 6
400026(0019)	Digital input 1	0 to 4
400027(001A)	Digital input 2	0 to 4
400028(001B)	Digital input 3	0 to 4
400029(001C)	Auto ref input selector	0 to 3
400030(001D)	Load resistance display method	0 to 1

400031(001E)	Operation	Bit0... Fault Bit1... I-OC Bit2... Over current Bit3... Over volt Bit4... Over temperature Bit5... Fuse cut Bit6... Phase loss Bit7... Load open Bit8... Over SCR Bit9... Over Frequency Bit10... Run/Stop Bit11... Auto/Manual Bit12... EMS Power
400032(001F)	Output slope (%)	*0.001(0 to 1.000)
400033(0020)	Output (%) for input 0%	*0.01(0 to 1000)
400034(0021)	Input correction	*0.1(-999 to 999)
400035(0022)	Input slope correction	*0.1(-999 to 999)
400036(0023)	Overcurrent alarm output	0 to 2 (*1)
400037(0024)	Current alarm output	0 to 2
400038(0025)	Overvoltage alarm output	
400039(0026)	Burn out fuse alarm	
400041(0028)	Heat sink temperature abnormal condition alarm	
400042(0029)	Element error alarm	
400044(002B)	Heater break alarm	

Distributor



ООО "РусАвтоматизация"

454010 Россия, Челябинск, Гагарина 6

Тел:(351) 751-12-71, +7 951 126 58 53

Тел./факс: (351) 211-64-57

e-mail: info@rusautomation.ru <http://www.rusautomation.ru>

Autonics

Sensors & Controllers

www.autonics.com

© Headquarters

116, Ungbigongdan-gil, Yangsan-si, Gyeongsangnam-do, Korea

▣ Overseas Sales Dept.

#402-404, Bucheon Techno Park, 655, Pyeongcheon-ro, Wonmi-gu, Bucheon, Gyeonggi-do, Korea
Tel: 82-32-610-2730 / Fax: 82-32-329-0728 / E-mail: sales@autonics.com

■ Brazil Autonics do Brasil Comercial Importadora Exportadora Ltda

Tel : 55-11-2307-8480 / Fax: 55-11-2309-7784/ E-mail: vendas@autonics.com.br

■ China Autonics electronic(Jiaxing) Corporation

Tel: 86-573-8216-1900 / Fax: 86-573-8216-1917 / E-mail: china@autonics.com

■ India Autonics Corporation - India Liaison Office

Tel : 91-22-2781-4305 / Fax : 91-22-2781-4518 / E-mail: india@autonics.com

■ Indonesia PT. Autonics Indonesia

Tel: 62-21-658 66 740 / Fax: 62-21-658 66 741 / E-mail: indonesia@autonics.com

■ Japan Autonics Japan Corporation

Tel: 81-265-79-8570 / Fax: 81-265-79-2442 / E-mail: support@autonicsjp.co.jp

■ Malaysia Mal-Autonics Sensor Sdn. Bhd.

Tel : 60-3-7805-7190(Hunting) / Fax : 60-3-7805-7193 / E-mail: malaysia@autonics.com

■ Mexico Autonics Mexico Sales Office

Tel : 52-55-5207-0019 / Fax : 52-55-1663-0712 / E-mail: ventas@autonics.com

■ Russia Autonics Corp. Russia Representative Office

Tel/Fax : 7-495-660-10-88 / E-mail : russia@autonics.com

■ Turkey Autonics Otomasyon Ticaret Ltd. Sti.

Tel : 90-216-365-9117 / Fax : 90-216-365-9112 / E-mail : info@autonics.com.tr

■ USA Autonics USA, Inc.

Tel: 1-847-680-8160 / Fax: 1-847-680-8155 / E-mail: sales@autonicsusa.net

■ Vietnam Autonics Vietnam Representative Office

Tel : 84-8-3771-2662 / Fax: 84-8-3771-2663 / E-mail: vietnam@autonics.com

Major products

- Photoelectric sensors •Fiber optic sensors •Door sensors •Door side sensors •Area sensors •Proximity sensors •Pressure sensors
- Rotary encoders •Connectors/sockets •Temperature controllers •Temperature/Humidity transducers •SSR/Power controllers
- Counters-Timers-Panel meters •Tachometer/Pulse(Rate)meters •Display units •Sensor controllers •Switching mode power supplies
- Control switches/Lamps/Buzzers •I/O Terminal Blocks & Cables-Stepper motors/drivers/motion controllers •Graphic/Logic panels
- Field network devices-Laser marking system(Fiber, CO₂, Nd:YAG) •Laser welding/soldering system
- Recorders/Indicators • Converters •Controllers-Thyristor units •Pressure transmitters •Temperature transmitters

■ Any proposal for product improvement and development : product@autonics.com